



VISHAY INTERTECHNOLOGY, INC.

INTERACTIVE

data book

INDUCTORS AND TRANSFORMERS

VISHAY AZTRONIC

VSD-DB0039-0210

Notes:

1. To navigate:
 - a) Click on the Vishay logo on any datasheet to go to the Contents page for that section. Click on the Vishay logo on any Contents page to go to the main Table of Contents page.
 - b) Click on the products within the Table of Contents to go directly to the datasheet.
 - c) Use the scroll or page up/page down functions.
 - d) Use the Adobe® Acrobat® page function in the browser bar.
2. To search the text of the catalog use the Adobe® Acrobat® search function.



VISHAY INTERTECHNOLOGY, INC.

DATA BOOK

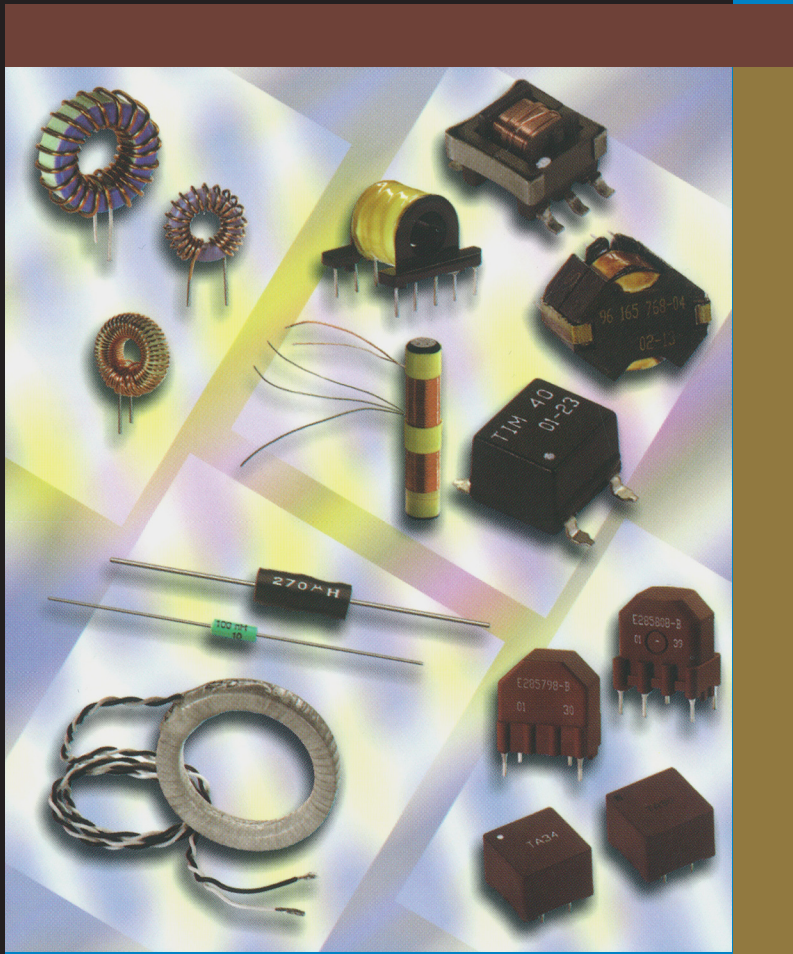

INDUCTORS AND TRANSFORMERS

Vishay Aztronic

VISHAY INTERTECHNOLOGY, INC.

DISCRETE SEMICONDUCTORS

RECTIFIERS	Schottky (single, dual) Standard, Fast and Ultra-Fast Recovery (single, dual) Clamper/Damper Bridge Superectifier® Sinterglass Avalanche Diodes
SMALL-SIGNAL DIODES	Schottky and Switching (single, dual) Tuner/Capacitance (single, dual) Bandswitching PIN
ZENER & SUPPRESSOR DIODES	Zener Diodes (single, dual) TVS (TransZorb®, Automotive, ESD, Arrays)
MOSFETs	Power MOSFETs JFETs
RF TRANSISTORS	Bipolar Transistors (AF and RF) Dual Gate MOSFETs MOSMICs®
OPTOELECTRONICS	IR Emitters, Detectors and IR Receiver Modules Opto Couplers and Solid State Relays Optical Sensors LEDs and 7 Segment Displays Infrared Data Transceiver Modules Custom products
ICs	Power ICs Analog Switches

PASSIVE COMPONENTS

CAPACITORS	Tantalum Capacitors Solid Tantalum Capacitors Wet Tantalum Capacitors Ceramic Capacitors Multilayer Chip Capacitors Disc Capacitors Film Capacitors Power Capacitors Heavy Current Capacitors Aluminum Capacitors Silicon Capacitors
RESISTIVE PRODUCTS	Foil Resistors Film Resistors Thin Film Resistors Thick Film Resistors Metal Oxide Film Resistors Carbon Film Resistors Wirewound Resistors Variable Resistors Cermet Variable Resistors Wirewound Variable Resistors Conductive Plastic Variable Resistors Networks/Arrays Non-Linear Resistors NTC Thermistors PTC Thermistors Varistors
MAGNETICS	Inductors Transformers

INTEGRATED MODULES

DC/DC CONVERTERS	
-------------------------	--

STRAIN SENSORS AND TRANSDUCERS

STRAIN GAGES AND INSTRUMENTS	
PHOTOSTRESS® INSTRUMENTS	
TRANSDUCERS	Load Cells Weighing Systems

ONE OF THE WORLD'S LARGEST MANUFACTURERS OF DISCRETE SEMICONDUCTORS AND PASSIVE COMPONENTS

Inductors and Transformers

Vishay Aztronic

Vishay S.A.

199, bd de la Madeleine

B.P. 1159

06003 Nice Cedex 1

France

Phone: +33 4 93 37 27 27

Fax: +33 4 93 37 27 26

www.vishay.com

NOTICE

The information in this catalog has been carefully checked for accuracy, and though it is believed to be correct, no warranty, either express or implied, is made as to either its applicability to, or its compatibility with, specific requirements; nor does Vishay Intertechnology, Inc. and its affiliates assume any responsibility for correctness of this information, nor for damages consequent to its use.

All such printed materials are not legally binding unless confirmed in writing pursuant to §§463 and 480 11 of the German Code of Civil Law.

Warning Regarding Life Support Applications

Not all products listed in this catalog are generally recommended for use in life support systems where a failure or malfunction of the component may directly threaten life or cause injury.

The user of products in such applications assumes all risks of such use and will agree to hold Vishay Intertechnology, Inc. and all the companies whose products are represented in this catalog, harmless against all damages.



INDUCTORS AND TRANSFORMERS

Quick Reference Guide.....	3
Product Identification	9

INDUCTORS

EC22	axial conformal coated inductors	12
EC24	axial conformal coated inductors	14
EC36	axial conformal coated inductors	16
EC46	axial conformal coated inductors	18
TR021	axial molded inductors	20
TR022	axial molded inductors	22
TR023	axial molded inductors	24
TR025	axial molded inductors	26
TR026	axial molded inductors	28
TRB021	axial molded shielded inductors.....	30
TRB023	axial molded shielded inductors.....	32
IG70	axial high current inductors.....	34
IG120	axial high current inductors.....	36
CH70	radial high current inductors	38
CH90	radial high current inductors	40
CH110	radial high current inductors	42
SK12	toroidal filter inductors.....	44
SK15	toroidal filter inductors.....	45
SK24	toroidal filter inductors.....	46
SK30	toroidal filter inductors.....	47
SK40	toroidal filter inductors.....	48
SC03	toroidal common mode inductors.....	49
SC04	toroidal common mode inductors.....	50
SC05	toroidal common mode inductors.....	51
SC06	toroidal common mode inductors.....	52

DATA AND VOICE ACCESS TRANSFORMERS

TLB51	wide band transformers	54
TIM 10, 20, 40	pulse transformers	55
TIR6	pulse transformers	56
TCV5	signal or DC/DC microconverter - SMD transformers/inductors.....	57
TCV11	signal or DC/DC microconverter - SMD transformers/inductors.....	58
TCV14	signal or flyback microconverter - SMD transformers/inductors	59
TCV14U1	signal or flyback microconverter - SMD transformers.....	60
TU2091	U interface transformers	61
TLP13 600, 300, 150	line matching transformers.....	62
TA32	impedance transformers	63



INDUCTORS AND TRANSFORMERS (CONTINUED)

TA34	impedance transformers	64
TA34M	impedance transformers	65
TA90	impedance transformers	66

CURRENT TRANSFORMERS

TCM50	current micro transformers	68
TCP7	current micro transformers.....	69
TCB	low frequency current transformers	71
TCH	high frequency current transformers.....	72

POWER SUPPLY TRANSFORMERS

TAZ	toroidal transformers	74
TMS	safety transformers	76
TRC 100, 200	low profile transformers.....	78
TRH	low profile transformers.....	79

INDUCTORS



CONFORMAL COATED INDUCTORS, AXIAL LEADS									
SERIES AND STYLES	DOCUMENT NO.	L μ H	TOL. \pm %	I MAX. mA	DCR MAX. Ω	Q MIN	SRF MIN. MHz	DIMENSIONS mm MAX.	
								\varnothing	L
EC22	59003	0.1 ... 220	20 10	400 ... 35	0.3 ... 20	35 ... 40	450 ... 5	3	4
EC24	59004	0.1 ... 1000		700 ... 60	0.085... 30	30 ... 60	280 ... 1.15	3.2	7
EC36	59005	0.1 ... 1000		900 ... 100	0.15 ... 17.4	25 ... 70	320 ... 1.4	4	10
EC46	59006	1000 ... 39000		-	8 ... 270	80 ... 40	-	5	10

Application: commercial

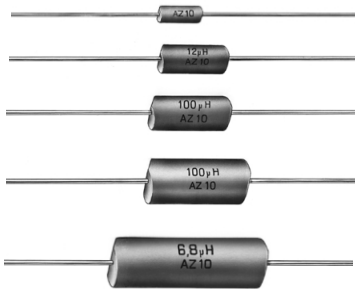

MOLDED INDUCTORS, AXIAL LEADS									
TR021	59007	0.022...1500	10 5 2	2530 ... 45	0.028 ... 80	40 ... 20	650 ... 1.2	2.42	6.35
TR022	59008	0.22 ... 1200		2600 ... 94	0.027 ... 20	45 ... 65	550 ... 3.2	3.94	9.53
TR023	59009	0.15 ... 1200		3160 ... 120	0.030 ... 17	50 ... 60	500 ... 2.6	5	11
TR025	59010	1 ... 8200		1900 ... 80	0.14 ... 72	65 ... 70	200 ... 0.75	6.35	14.25
TR026	59011	1.2 ... 1200		3150 ... 170	0.075 ... 25	60 ... 80	170 ... 4.7	7.12	22.86

Application: filters, tuners

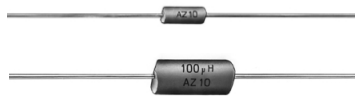

MOLDED SHIELDED INDUCTORS, AXIAL LEADS									
TRB021	59012	0.1 ... 47	10	1340 ... 255	0.1 ... 2.8	30 ... 45	200 ... 20	2.42	6.35
TRB023	59013	0.1 ... 1200		4300 ... 110	0.008 ... 27	50 ... 45	250 ... 2.5	5	11

Application: filters, tuners



PROTECTED CURRENT CHOKES, AXIAL LEADS									
IG70	59014	1 ... 18000	20	5300 ... 80	0.009 ... 40	-	-	7	18
IG120	59015	3.9... 100000		4000 ... 70	0.007 ... 70	-	-	12	23

Application: high current filters, power supplies



CONFORMAL COATED INDUCTORS, AXIAL LEADS									
CH70	59016	1 ... 1000	10	1030 ... 100	0.20 ... 115	60 ... 55	105 ... 1.6	7	9
CH90	59017	100 ... 100000		343 ... 12	0.85 ... 295	45 ... 30	4.3 ... 0.1	9	12
CH110	59018	1 ... 15000		6400... 100	0.004 ... 15	10 ... 50	85...0.29	11	12

Application: high current filters, tuners, power supplies

INDUCTORS (CONTD.)



TOROIDAL FILTER INDUCTORS						
SERIES AND STYLES	DOCUMENT NO.	I MAX. A	L WITH RATED CURRENT μ H	L WITHOUT LOAD μ H	DCR MAX. $m\Omega$	Dim.
SK12	59019	2 ... 0,2	7 ... 700	10 ... 1000	20 ... 1590	Consult detailed datasheets
SK15	59020	4 ... 0,315	7 ... 700	10 ... 1000	14 ... 1978	
SK24	59021	6 ... 0,7	7 ... 700	10 ... 1000	8 ... 871	
SK30	59022	8 ... 0,8	7 ... 700	10 ... 1000	15 ... 1465	
SK40	59023	15 ... 1,75	7 ... 700	10 ... 1000	7 ... 681	

Application: filters, power supplies



TOROIDAL COMMON MODE INDUCTORS						
SERIES AND STYLES	DOCUMENT NO.	WINDING NUMBER : 2 PER WINDING		I MAX. A	DIMENSIONS	
		L mH	DCR max. $m\Omega$		H x L x l mm^3	
SC03	59024	47 ... 0.47	4100 ... 37	0.3 ... 3,5	V	20 x 18 x 13
					H	12 x 18 x 17
SC04	59025	47 ... 0.47	2600 ... 30	0.3 ... 5	V	25 x 23 x 16
					H	15 x 23 x 22
SC05	59026	47 ... 0.47	1100 ... 35	0.6 ... 4	V	30 x 28 x 18
					H	18 x 28 x 27
SC06	59027	47 ... 0.47	1050 ... 40	0.7 ... 6	V	35 x 32 x 18
					H	20 x 33 x 32

Application: symmetrical and assymetrical line filters



WIDEBAND CHOKES				
SERIES AND STYLES	DOCUMENT NO.	IMPEDANCE Ω	NUMBER OF TURNS	DIMENSIONS D x L mm^2
IWB 15	59030	400	1.5	6 x 10
IWB 25		700	2.5	6 x 10
IWB 30		1000	3	6 x 10

Application: noise suppression

INDUCTORS (CONTD.)



HIGH POWER COMMON MODE INDUCTORS									
SERIES AND STYLES	DOCU MENT NO.	IMPEDANCE MH	NOMINAL CURRENT		WINDING RESISTANCE MΩ		DIMENSIONS (mm)		
			SP 70	SP 80	SP 70	SP 80	H	DIA	
SP 70	single phase	59031	2 x 0.47	25	75	5	2	40	71
			2 x 1	20	50	7	3		
			2 x 2.2	16	37	12	6		
			2 x 4.7	10	25	24	11		
			2 x 10	8	17	44	21		
SP 80	three phases	59032	3 x 0.27	17	55	8	2	72	82
			3 x 0.47	13	45	11.3	3		
			3 x 1	10	30	20	4.5		
			3 x 4.7	7	15	39	18		
			3 x 10	5.5	11	71	34		

Application: electrical and electronic high power filters

DATA AND VOICE ACCESS TRANSFORMERS

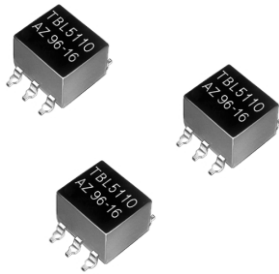

WIDEBAND TRANSFORMERS						
SERIES AND STYLES	DOCU MENT NO.	PRIMARY / SECONDARY RATIO	FREQUENCY MAX. MHz	I MAX. mA	CASE	DIMENSIONS (mm) H x L x W
TLB 5110	59047	1/1	360	100	6 pins 2.54 lead spacing	5.6 x 11 x 7.7
TLB 5115		1/1.5	153			
TLB 5125		1/2.5	190			
TLB 5140		1/4	160			

Application: signal transfer in high frequency



PULSE TRANSFORMERS							
SERIES AND STYLES	DOCU MENT NO.	PRIMARY / SECONDARY RATIO	FREQUENCY MAX. KHZ	ET FACTOR V μS	IP MAX. mA	FERRITE	DIMENSIONS (mm) H x L x W
TIM 10	59045	1	300	3.5	200	4 pins 2.54 lead spacing	5.6 x 11 x 7.7
TIM 20		2		3.5	200		
TIM 40		4		4	400		

Application: general use



SERIES AND STYLES	DOCU MENT NO.	RATIO IMPEDANCE	ET FACTOR V μS	IP MAX. MA	FERRITE	DIMENSIONS (mm) H x L x W
TIR 6-10	59046	1/1	1000	75	RM6	12 x 15 x 15
TIR-6-20		1/2	600	100		
TIR-6-40		1/4	500	140		



DATA AND VOICE ACCESS TRANSFORMERS (CONTD.)

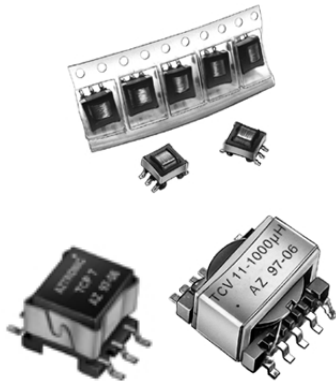

SIGNAL OR MICROCONVERTER TRANSFORMERS

SERIES AND STYLES	DOCUMENT NO.	STYLE	WINDING NUMBER	DIELECTRIC STRENGTH V	FREQUENCY MAX. kHz	POWER VA	DIMENSIONS (mm) H x L x W
TCV 5	59044	E 5	1	1000	300	0.5	5.2 x 8.2 x 6.5
TCV 11	59041	ER 11	2			5.6	6.3 x 13.4 x 12
TCV 14	59042	ER 14	2			14	8.5 x 17.7 x 15.4
TCV14U1	59043	ER 14	5			14	8.5 x 16.5 x 15.4

Application: switching and filtering for microconverter

U INTERFACE TRANSFORMER



SERIES AND STYLES	DOCUMENT NO.	U INTERFACE	TRANSFORMER RATIO	DIMENSIONS (mm) H x L x W
TU 2091	59052	LB 3T 2B 1Q	0.8 / 1 / 0.8	16.5 x 16.5 x 20

Application: ISDN

LINE MATCHING TRANSFORMERS



SERIES AND STYLES	DOCUMENT NO.	APPROVAL	TRANSMISSION SPEED BAUDS	IMPEDANCE	DIMENSIONS (mm) H x L x W
TLP 13-600	59048	V 22 bis	2400	600/600	14 x 14 x 14
TLP 13-300			2400	600/300	
TLP 13-150			2400	600/150	

IMPEDANCE TRANSFORMERS

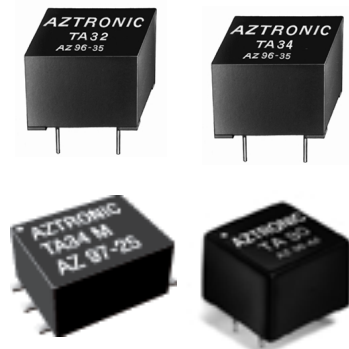

SERIES AND STYLES	DOCUMENT NO.	APPROVAL	TRANSMISSION SPEED BAUDS	IMPEDANCE	DIMENSIONS (mm) H x L x W
TA32	59033	V 32	14400	600/600	14 x 18 x 18
TA34	59034	V 34	28800		12.5 x 9.6 x 7.1
TA34M	59035	V34	28800		14 x 18 x 18
TA90	59053	V90	56000		

Application: modems telecom lines

CURRENT TRANSFORMERS



MICROTRANSFORMERS						
SERIES AND STYLES	DOCUMENT NO.	FREQUENCY kHz	RATIO	I MAX. A	DIELECTRIC STRENGTH VRMS	DIMENSIONS (mm) H x L x W
TCM 50	59039	10 to 100	1 V/A 50 load	2	1000	9.3 x 11 x 7.7
TCP 7	59040	20 to 100	1 V/A 100 load	15	1500	9 x 9 x 9

Application: current measurement for microconverter



LOW FREQUENCY TRANSFORMERS						
SERIES AND STYLES	DOCUMENT NO.	FREQUENCY HZ	RATIO	I MAX. A	DIELECTRIC STRENGTH VRMS	DIMENSIONS (mm) H x L x W
TCB 50	59037	50	0.07 V/A 33 load	50	2000	30 x 28 x 18
TCB 70			0.07 V/A 50 load	70		
TCB 100		60	0.05 V/A 50 load	100		

Application: 50/60Hz current measurement

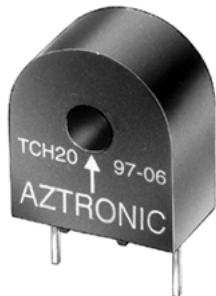

HIGH FREQUENCY TRANSFORMERS						
SERIES AND STYLES	DOCUMENT NO.	FREQUENCY kHz	RATIO	I MAX. A	DIELECTRIC STRENGTH VRMS	DIMENSIONS (mm) H x L x W
TCH 5	59038	10 to 100	1 V/A 50 load	5	4000	21 x 17.5 x 9.5
TCH 10			0.5 V/A 50 load	10		
TCH 20			0.25 V/A 50 load	20		

Application: high frequency current measurement



CURRENT TRANSFORMERS



TOROIDAL TRANSFORMERS						
SERIES AND STYLES	DOCUMENT NO.	SECONDARY VOLTAGE	FIXATION	UNIT WEIGHT	DIMENSIONS (mm)	
					Dia.	High.
TAZ 15	59036	2 x 6 V to 2 x 48 V	CFM 4 x 40	320g	63	31
TAZ 30			CFM 4 x 40	520g	72	32
TAZ 50			CFM 6 x 40	730g	82	33
TAZ 80			CFM 6 x 50	1000g	90	42
TAZ 120			CFM 6 x 50	1500g	102	37
TAZ 160			CFM 6 x 50	1700g	105	43
TAZ 200			CFM 8 x 50	2100g	118	42
TAZ 250			CFM 8 x 70	3000g	125	60
TAZ 300			CFM 8 x 70	3400g	130	60
TAZ 500			CFM 10 x 60	4300g	145	55

Application: general use 50Hz - 60Hz



TOROIDAL TRANSFORMERS					
SERIES AND STYLES	DOCUMENT NO.	SECONDARY VOLTAGE	FIXATION	UNIT WEIGHT	DIMENSIONS (mm)
					L x W x H
TMS 0.5	59049	6V to 24V	Case	42g	32 x 34.2 x 15.3
TMS 1			Case	70g	32 x 34.2 x 21.8
TMS 1.2			Case	80g	32 x 34.2 x 23.8
TMS 1.8			Case	96g	32 x 34.2 x 26.8
TMS 2.5			Case	110g	32 x 34.2 x 29.5
TMS 3.2			Case	150g	40.2 x 34.5 x 28.1
TMS 5			Case	195g	44.1 x 36.9 x 32.5

Application: general use 50Hz - 60Hz



LOW PROFILE TRANSFORMERS			
SERIES AND STYLES	DOCUMENT NO.	POWER MAX.	DIMENSIONS (mm) H x L x I
TRC 100	59050	150 W	10 x 35 x 34
TRC 20		300 W	10 x 50 x 47
TRH $\begin{cases} 22 \\ 64 \end{cases}$	59051	100 W to 500 W	See data sheet

Application: professional avionic

Standard Decade Inductance Values

COLOR CODE			
COLOR	SIGNIFICANT FIGURE	VALUE MULTIPLIER	INDUCTANCE TOLERANCE
Black	0	1	
Brown	1	10	
Red	2	100	
Orange	3	1000	
Yellow	4	–	
Green	5	–	
Blue	6	–	
Purple	7	–	
Grey	8	–	
White	9	–	
Black	–	–	± 20%
Silver	–	0.01	± 10%
Gold	–	0.1	± 5%

EC22 SERIES

Marking 3 color bands.

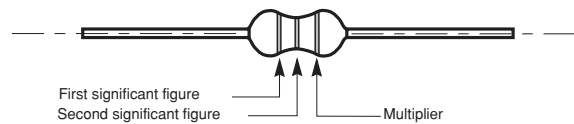

EC24, EC36, EC46, TR021, TR022, TR023, TR025, TR026, TRB021, TRB023 SERIES

Marking 4 color bands.

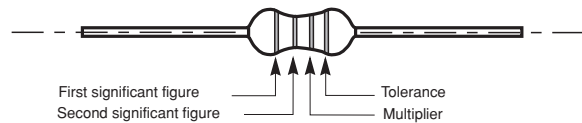

STANDARD DECADE INDUCTANCE VALUES

E12 series - Multiples and submultiples

100 - 120 - 150 - 180 - 220 - 270 - 330 - 390 - 470 - 560 - 680 - 820.



Inductors

Axial or Radial Terminations

•

Molded or Conformal Construction

•

Toroidal Filter and Common Mode Styles



Model Numbers

EC22	12
EC24	14
EC36	16
EC46	18
TR021	20
TR022	22
TR023	24
TR025	26
TR026	28
TRB021	30
TRB023	32
IG70	34
IG120	36
CH70	38
CH90	40
CH110	42
SK12	44
SK15	45
SK24	46
SK30	47
SK40	48
SC03	49
SC04	50
SC05	51
SC06	52

Conformal Coated Inductors, Axial Leads, Commercial Use



FEATURES

- Miniature style
- Uniform epoxy coating for humidity
- Copper winding on magnetic core structure
- Tinned copper axial leads.

DIMENSIONS in millimeters

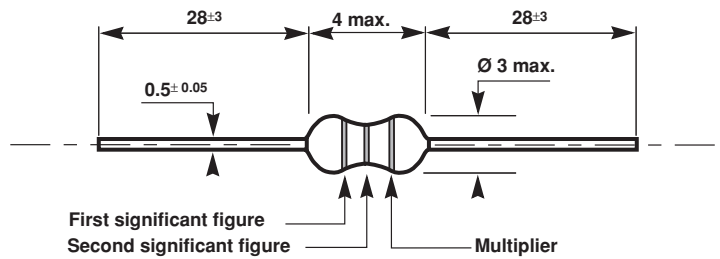

ELECTRICAL SPECIFICATIONS	
Inductance Range	0.1 μ H to 220 μ H
Tolerance	$\pm 20\%$ $0.1 \mu\text{H} < L \leq 0.56 \mu\text{H}$ $\pm 10\%$ $0.68 \mu\text{H} < L \leq 220 \mu\text{H}$
Limiting Voltage	250VRMS

MECHANICAL SPECIFICATIONS

Coating	epoxy resin
Terminations	tinned copper
Weight	0.15g

ENVIRONMENTAL SPECIFICATIONS

Operating Temperature	+ 80°C
Temperature Limits	- 20°C + 100°C



EC22 INDUCTORS - STANDARD VALUES				
INDUCTANCE VALUE μH	TOLERANCE %	Q MIN.	TEST FREQUENCY MHz	DCR MAX. Ω
0.1	$\pm 20\%$	40	25.2	0.03
0.12				0.03
0.15				0.035
0.18				0.035
0.22				0.045
0.27				0.045
0.33				0.045
0.39				0.060
0.47				0.076
0.56	$\pm 20\%$			0.08
0.68	$\pm 10\%$			0.09
0.82				0.12
1			25.2	0.15
1.2		40	7.96	0.20
1.5		30		0.25
1.8				0.25
2.2				0.35
2.7				0.35
3.3				0.45
3.9				0.45
4.7				0.65
5.6				0.80
6.8		30		0.95
8.2		25		1
10		30	7.96	1
12		40	2.52	1.5
15				1.8
18				1.8
22				2
27				2.5
33				3
39				3.5
47				4.5
56				5
68				8
82				8
100			2.52	11
120			0.796	11
150				14
180		40		14
220	$\pm 10\%$	50	0.796	25

PACKAGING
2000 pieces tape in box "ammopack" 5000 pieces tape and reel On request : 2000 pieces tape and reel radial style available(consult VISHAY AZTRONIC for dimensions).

MARKING
3 color band.

ORDERING INFORMATION				
EC	22	0.47μH	$\pm 20\%$	B
SERIES	STYLE	INDUCTANCE VALUE	TOLERANCE	PACKAGING
				R: tape and reel B: tape in box "Ammopack" E: radial style

Conformal Coated Inductors, Axial Leads, Commercial Use



FEATURES

- Uniform epoxy coating for humidity
- Copper winding on magnetic core structure
- Tinned copper axial leads

DIMENSIONS in millimeters

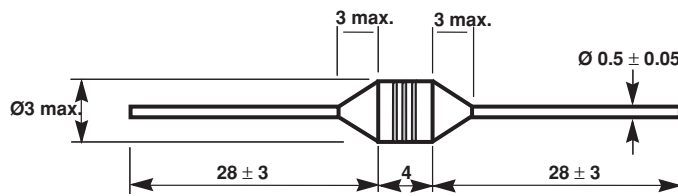

ELECTRICAL SPECIFICATIONS	
Inductance Range	0.1 μ H to 1000 μ H
Tolerance	$\pm 20\%$ 0.1 μ H < L \leq 0.82 μ H $\pm 10\%$ 1 μ H < L \leq 1000 μ H
Limiting Voltage	250VRMS

MECHANICAL SPECIFICATIONS

Coating	epoxy resin
Terminations	tinned copper
Weight	0.25g

ENVIRONMENTAL SPECIFICATIONS

Operating Temperature	+ 80°C
Temperature Limits	- 20°C + 100°C



EC24 INDUCTORS - STANDARD VALUES						
INDUCTANCE VALUE μH	TOLERANCE %	Q MIN.	TEST FREQUENCY MHz	DCR MAX. Ω	SRF MIN. MHz	I MAX. mA
0.10	$\pm 20\%$	30	25.2	0.085	280	700
0.12				0.085	280	
0.15		↓		0.095	280	
0.18		30		0.12	280	
0.22		40		0.15	280	
0.27				0.15	260	
0.33				0.15	250	
0.39				0.17	220	
0.47				0.17	200	
0.56				0.17	180	
0.68	↓			0.18	160	
0.82	$\pm 20\%$			0.18	140	
1	$\pm 10\%$		25.2	0.18	135	
1.2			7.96	0.18	135	↓
1.5				0.20	130	700
1.8				0.23	125	655
2.2				0.25	80	630
2.7				0.28	80	595
3.3				0.30	70	575
3.9				0.32	65	555
4.7				0.35	45	530
5.6				0.40	49	500
6.8				0.45	30	470
8.2			↓	0.56	28	425
10			7.96	0.72	22	370
12			2.52	0.80	20	350
15				0.88	16	335
18				1	15	315
22				1.20	13	285
27				1.35	11	270
33		↓		1.50	10	255
39		40		1.70	9.5	240
47		50		2.30	8.5	205
56				2.60	7.5	195
68				2.90	6.5	185
82		↓	↓	3.20	6	175
100		50	2.52	3.50	5.5	165
120		60	0.796	3.80	5.4	160
150				4.40	4.75	150
180				5	4.35	140
220				5.70	4	130
270				7.50	3.7	120
330				9.50	3.4	100
390				10.5	2.8	95
470				11.6	2.56	90
560				13	2.35	85
680		↓		18	2	75
820		60	↓	23.7	1.60	65
1000	$\pm 10\%$	50	0.796	30	1.15	60

PACKAGING

2000 pieces tape in box "ammopack"
5000 pieces tape and reel
On request : 2000 pieces tape and reel radial style available (consult VISHAY AZTRONIC for dimensions).

MARKING

4 color band.

ORDERING INFORMATION

EC	24	0.47μH	$\pm 20\%$	B
SERIES	STYLE	INDUCTANCE VALUE	TOLERANCE	PACKAGING
				R: tape and reel B: tape in box "Ammopack" E: radial style

Conformal Coated Inductors, Axial Leads, Commercial Use

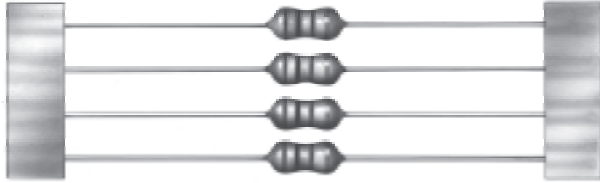

FEATURES

- Uniform epoxy coating for humidity
- Copper winding on magnetic core structure
- Tinned copper axial leads

DIMENSIONS in millimeters

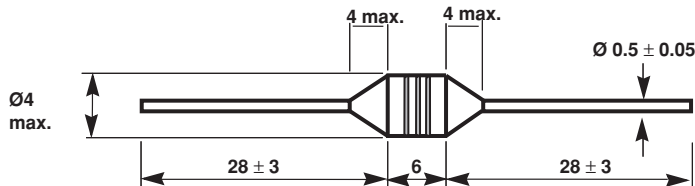

ELECTRICAL SPECIFICATIONS	
Inductance Range	0.1 μ H to 1000 μ H
Tolerance	$\pm 20\%$ 0.1 μ H < L \leq 0.82 μ H $\pm 10\%$ 1 μ H < L \leq 1000 μ H
Limiting Voltage	250VRMS

MECHANICAL SPECIFICATIONS

Coating	epoxy resin
Terminations	tinned copper
Weight	0.5g

ENVIRONMENTAL SPECIFICATIONS

Operating Temperature	+ 80°C
Temperature Limits	- 20°C + 100°C



EC36 INDUCTORS - STANDARD VALUES						
INDUCTANCE VALUE μH	TOLERANCE %	Q MIN.	TEST FREQUENCY MHz	DCR MAX. Ω	SRF MIN. MHz	I MAX. mA
0.10	± 20 %	25	25.2	0.15	320	900
0.12				0.16		900
0.15				0.17	↓	890
0.18				0.19	320	890
0.22				0.21	300	880
0.27				0.24	300	800
0.33				0.28	300	750
0.39				0.32	280	680
0.47				0.36	250	650
0.56				0.41	230	600
0.68	↓	25	↓	0.47	210	550
0.82	± 20%	45	↓	0.24	172	980
1	± 10%	45	25.2	0.24	157	920
1.2		50	7.96	0.27	144	880
1.5		50		0.3	131	830
1.8		55		0.32	121	790
2.2		55		0.35	110	750
2.7		60		0.35	100	720
3.3		65		0.35	94	670
3.9		65		0.37	86	640
4.7		70		0.39	80	620
5.6				0.43	74	590
6.8			↓	0.48	68	550
8.2			7.96	0.52	53	530
10			2.52	0.58	45	500
12				0.63	34	480
15		70		0.72	20	460
18		65		0.77	14	430
22		40		0.84	9.9	410
27		55		0.94	7.6	390
33		55		1.03	6.3	370
39		50		1.12	6.3	350
47		45		1.22	6.3	340
56		40		1.34	6.2	320
68		40		1.47	5.7	306
82		35	↓	1.62	5.3	290
100		30	2.52	1.8	4.8	275
120		70	0.796	3.7	3.8	185
150		70		4.2	3.5	175
180		70		4.6	3.3	165
220		70		5.1	3	155
270		65		5.8	2.8	146
330		65		6.4	2.6	137
390		65		7	2.4	133
470		60		7.7	2.25	126
560		60		8.5	2.1	120
680	↓	55	↓	9.4	1.95	113
820		55	0.796	12	1.85	100
1000	± 10%	50	0.252	17.4	1.4	100

PACKAGING

2000 pieces tape in box "ammopack"
5000 pieces tape and reel
On request : 2000 pieces tape and reel radial style available (consult VISHAY AZTRONIC for dimensions).

MARKING

4 color band.

ORDERING INFORMATION

EC	36	0.47μH	± 20%	B
SERIES	STYLE	INDUCTANCE VALUE	TOLERANCE	PACKAGING
				R: tape and reel B: tape in box "Ammopack" E: radial style

Conformal Coated Inductors, Axial Leads, Commercial Use

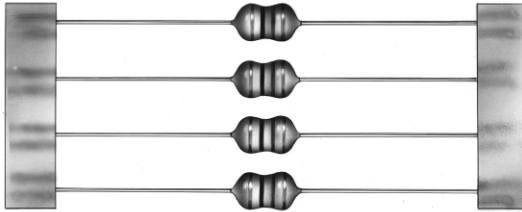

FEATURES

- Uniform epoxy coating for humidity
- Copper winding on magnetic core structure
- Tinned copper axial leads

DIMENSIONS in millimeters

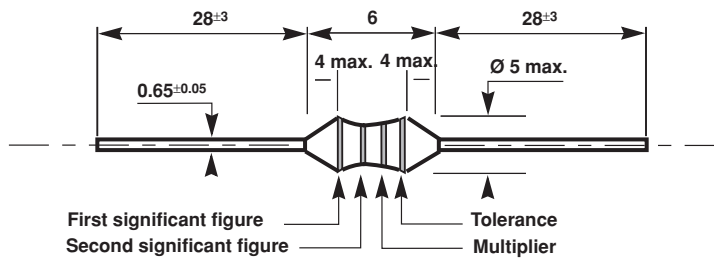

ELECTRICAL SPECIFICATIONS

Inductance Range	1mH to 39mH
Tolerance	$\pm 10\%$
Limiting Voltage	250VRMS

MECHANICAL SPECIFICATIONS

Coating	epoxy resin
Terminations	tinned copper
Weight	1g

ENVIRONMENTAL SPECIFICATIONS

Operating Temperature	+ 80°C
Temperature Limits	- 20°C + 100°C



EC46 INDUCTORS - STANDARD VALUES				
INDUCTANCE VALUE μH 1KHz	TOLERANCE %	Q MIN.	TEST FREQUENCY MHz	DCR MAX. Ω
1	± 10%	80	252	8
1.2				9
1.5				10
1.8				11
2.2				14
2.7				18
3.3				22
3.9		↓		26
4.7		80		30
5.6		60		34
6.8			↓	48
8.2			259	62
10			79.6	74
12		↓		88
15		60		102
18		40		150
22				180
27				210
30				240
33		↓	↓	250
39	± 10%	40	79.6	270

PACKAGING

2000 pieces tape in box "ammopack"
5000 pieces tape and reel
On request : 2000 pieces tape and reel radial style available (consult VISHAY AZTRONIC for dimensions).

MARKING

4 color band.

ORDERING INFORMATION

EC	46	15mH	± 10%	B
SERIES	STYLE	INDUCTANCE VALUE	TOLERANCE	PACKAGING
				R: tape and reel B: tape in box "Ammopack" E: radial style

Molded Inductors, Axial Leads, High Frequency and Noise Suppression Applications

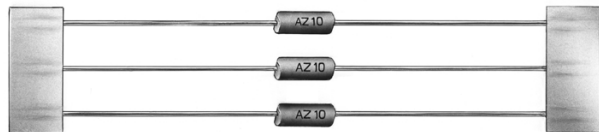

The inductors conform to NFC 93-331 regulation. They have copper winding on magnetic core structure with tinned copper lead terminals. Depending on inductance value core is either phenolic material, iron powder or ferrite.

FEATURES

- NF C 93-331 LNZ
- GAM-T-1 lists
- Accurate dimensions
- Superior moisture protection
- Flame retardant coating
- High-Rel version on request

DIMENSIONS in millimeters

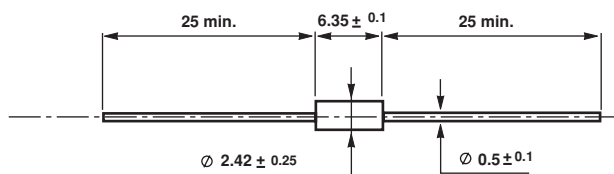

ELECTRICAL SPECIFICATIONS	
Inductance Range	0.022μH to 1500μH
Tolerance On Request	± 10% 0.022μH < L ≤ 1500μH ± 5% 1μH < L ≤ 1000μH ± 2% 1μH < L ≤ 1000μH
Maximum Voltage	500VRMS
Power Rating	180mW at + 70°C

MECHANICAL SPECIFICATIONS

Coating	flame retardant molded epoxy
Terminals	tinned copper
Weight	0.5g

ENVIRONMENTAL SPECIFICATIONS

Operating Temperature Range	+ 70°C
Temperature Limits	- 55°C + 125°C



Molded Inductors, Axial Leads,
High Frequency and Noise Suppression Applications

Vishay Aztronic

TR021 INDUCTORS - STANDARD VALUES						
INDUCTANCE VALUE μH	TOLERANCE %	Q MIN.	TEST FREQUENCY MHz	DCR MAX. Ω	SRF MIN. MHz	I MAX. mA
0.022	$\pm 10\%$	40	50	0.028	650	2530
0.027				0.030		2450
0.033				0.035		2270
0.039				0.035		2270
0.047				0.04		2120
0.056				0.05		1900
0.068				0.06		1730
0.082		40	50	0.07		1620
0.10		35	25	0.08	650	1500
0.12				0.09	620	1410
0.15				0.10	600	1340
0.18				0.12	550	1225
0.22				0.14	510	1130
0.27				0.16	430	1060
0.33				0.20	410	945
0.39				0.30	380	775
0.47				0.38	340	690
0.56				0.50	300	600
0.68				0.60	275	550
0.82				0.75	250	490
1			25	0.90	230	445
1.2			7.9	0.18	150	1000
1.5				0.22	140	905
1.8				0.30	125	775
2.2		35		0.40	115	670
2.7		40		0.50	100	600
3.3		45		0.80	90	475
3.9		45		1	82	425
4.7		45		1.2	75	385
5.6		50		1.8	68	330
6.8		55		1.8	60	330
8.2		55		2.55	55	265
10		55	7.9	2.9	50	245
12		45	2.5	1.9	45	305
15		50		2.8	45	250
18				3.1	40	240
22				3.3	40	230
27				3.9	30	215
33				4	24	210
39				4.4	22	200
47				5	20	190
56				5.3	18	180
68				6.1	15	170
82				6.9	14	160
100		50	2.5	7.7	11.5	150
120		40	0.79	9.9	9.5	135
150		40		11	8.5	120
180		30		18	8	100
220				21	7.2	90
270				25	6.4	85
330				34	5.6	70
390				42	4.5	65
470				46	4.2	60
560				52	3.5	55
680				55	3.3	55
820				62	3	50
1000		30	0.79	67	2.5	50
1200		20	0.25	74	1.6	45
1500	$\pm 10\%$	20	0.25	80	1.2	45

PACKAGING
Standard: tape packaging
250 pieces tape in box "Ammopack"
1000 pieces tape and reel.

MARKING
Standard: Print marked-manufacturer, inductance value, tolerance, or 4 color bands.

ORDERING INFORMATION					
TR SERIES	021 STYLE	6.8 μH INDUCTANCE VALUE	$\pm 10\%$ TOLERANCE $\pm 10\%$ $\pm 5\%$ $\pm 2\%$	R PACKAGING R: tape and reel B: tape in box "Ammopack"	OPTIONAL COLOR BANDS MARKING

Molded Inductors, Axial Leads, High Frequency and Noise Suppression Applications

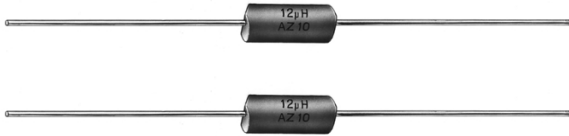

These inductors conform to NFC 93-331 regulation. They have copper winding on magnetic core structure with tinned copper lead terminals. Depending on inductance value core is either phenolic material, iron powder or ferrite.

FEATURES

- NF C 93-331 LNZ
- GAM-T-1 lists
- Accurate dimensions
- Superior moisture protection
- Flame retardant coating
- High Reliability version on request

DIMENSIONS in millimeters

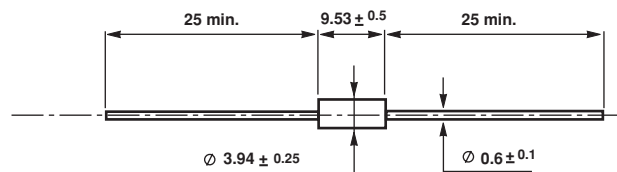

ELECTRICAL SPECIFICATIONS	
Inductance Range	0.1µH to 1000µH
Tolerance On Request	± 10% 0.1µH < L ≤ 1000µH ± 5% 1µH < L ≤ 1000µH ± 2% 1µH < L ≤ 1000µH
Maximum Voltage	500VRMS
Power Rating	180mW at + 70°C

MECHANICAL SPECIFICATIONS

Coating	flame retardant molded epoxy
Terminals	tinned copper
Weight	0.78g

ENVIRONMENTAL SPECIFICATIONS

Operating Temperature Range	+ 70°C
Temperature Limits	- 55°C + 125°C



TR022 INDUCTORS - STANDARD VALUES						
INDUCTANCE VALUE μ H	TOLERANCE %	Q MIN.	TEST FREQUENCY MHz	DCR MAX. Ω	SRF MIN. MHz	I MAX. mA
0.10	$\pm 10\%$	45	25	0.027	550	2600
0.12				0.029	530	2490
0.15				0.030	525	2450
0.18				0.042	500	2070
0.22				0.050	450	1900
0.27				0.075	410	1550
0.33				0.090	370	1400
0.39				0.10	310	1330
0.47				0.12	260	1225
0.56				0.14	250	1130
0.68				0.15	240	1100
0.82		45		0.22	220	900
1		50	25	0.24	200	860
1.2			7.9	0.20	170	950
1.5				0.21	150	925
1.8				0.23	135	885
2.2				0.24	125	865
2.7				0.21	110	925
3.3				0.25	105	850
3.9				0.27	95	815
4.7		50		0.29	90	790
5.6		45		0.32	60	750
6.8		45		0.47	55	630
8.2		50		0.57	50	560
10		55	7.9	0.90	45	445
12		60	2.5	1.10	40	400
15		60		1.30	38	370
18		65		2	34	300
22		75		2.2	30	275
27		75		2.6	25	260
33		75		2.65	22	255
39		70		2.70	18	250
47		70		2.90	15	245
56		70		3.10	14	240
68		65		3.40	12	230
82				3.90	11	215
100				4.50	10	200
120				5.20	9	185
150				5.80	8	175
180				6.50	7	165
220				7.20	6	158
240				7.40	6	155
270				8	5.7	150
330				9	5.5	140
390				10	5.3	135
470				15	5	110
560				15.5	4	108
680				16.5	3.8	104
820				18	3.6	100
1000	$\pm 10\%$	65	0.79	20	3.2	94

PACKAGING

Standard: tape packaging
250 pieces tape in box "Ammopack"
500 pieces tape and reel.

MARKING

Standard: Print marked-manufacturer, inductance value, tolerance, or 4 color bands.

ORDERING INFORMATION

TR SERIES	022 STYLE	12 μ H INDUCTANCE VALUE	$\pm 10\%$ TOLERANCE	R PACKAGING	OPTIONAL COLOR BANDS MARKING
			$\pm 10\%$ $\pm 5\%$ $\pm 2\%$	R: tape and reel B: tape in box "Ammopack"	

Molded Inductors, Axial Leads, High Frequency and Noise Suppression Applications

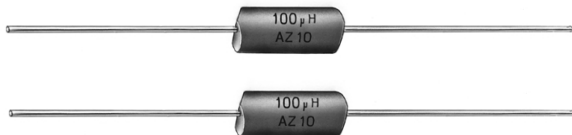

These inductors conform to NFC 93-331 regulation. They have copper winding on magnetic core structure with tinned copper lead terminals. Depending on inductance value core is either phenolic material, iron powder or ferrite.

FEATURES

- NF C 93-331 LNZ
- GAM-T-1 lists
- Accurate dimensions
- Superior moisture protection
- Flame retardant coating
- High reliability version on request

DIMENSIONS in millimeters

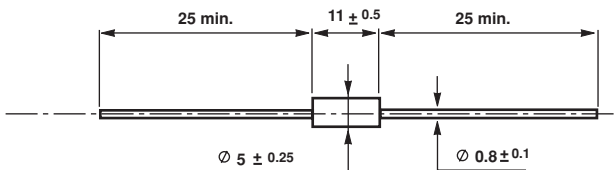

ELECTRICAL SPECIFICATIONS	
Inductance Range	0.15µH to 1000µH
Tolerance On Request	± 10% 0.15µH < L ≤ 1000µH ± 5% 1µH < L ≤ 1000µH ± 2% 1µH < L ≤ 1000µH
Maximum Voltage	500VRMS
Power Rating	300mW at + 70°C

MECHANICAL SPECIFICATIONS

Coating	flame retardant molded epoxy
Terminals	tinned copper
Weight	1.3g

ENVIRONMENTAL SPECIFICATIONS

Operating Temperature Range	+ 70°C
Temperature Limits	- 55°C + 125°C



TR023 INDUCTORS - STANDARD VALUES						
INDUCTANCE VALUE μ H	TOLERANCE %	Q MIN.	TEST FREQUENCY MHz	DCR MAX. Ω	SRF MIN. MHz	I MAX. mA
0.15	$\pm 10\%$	50	25	0.030	500	3160
0.18				0.032	410	3060
0.22				0.035	400	2920
0.27				0.050	380	2440
0.33				0.065	340	2150
0.39				0.075	320	2000
0.47				0.085	300	1870
0.56		↓		0.14	250	1470
0.68		50		0.15	230	1415
0.82		45	↓	0.22	220	1165
1		45	25	0.30	190	1000
1.2		30	7.9	0.40	180	870
1.5				0.42	170	850
1.8				0.65	150	680
2.2		↓		0.79	135	620
2.7		30		1.20	120	500
3.3		35		0.14	75	1465
3.9				0.15	55	1415
4.7				0.21	50	1200
5.6				0.28	50	1035
6.8				0.37	50	900
8.2		↓	↓	0.44	45	825
10		35	7.9	0.60	33	700
12		50	2.5	1	33	545
15		45		1.30	30	480
18		60		1.10	35	510
22				1.20	30	500
27				1.30	22	480
33				1.50	20	430
39				1.70	18	420
47				2.10	17	375
56				2.35	14	355
68				2.80	12	325
82			↓	3.30	11	300
100			2.5	3.60	10	285
120			0.79	5	6.5	245
150				6.1	5.5	220
180				7.5	5.5	200
220				8.4	5.5	185
270				9	5	180
330				10	4.5	170
390				11	4.3	165
470				12	4	155
560				13	3.5	150
680				14	3.3	145
820		↓	↓	16	3	135
1000	$\pm 10\%$	60	0.79	17	2.6	120

PACKAGING
 Standard: tape packaging
 250 pieces tape in box "Ammopack"
 1000 pieces tape and reel.

MARKING
 Standard: Print marked-manufacturer, inductance value, tolerance, or 4 color bands.

ORDERING INFORMATION					
TR SERIES	023 STYLE	12 μ H INDUCTANCE VALUE	$\pm 10\%$ TOLERANCE	R PACKAGING	OPTIONAL COLOR BANDS MARKING
			$\pm 10\%$ $\pm 5\%$ $\pm 2\%$	R: tape and reel B: tape in box "Ammopack"	

Molded Inductors, Axial Leads, High Frequency and Noise Suppression Applications

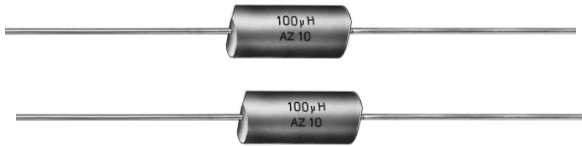

These inductors conform to NFC 93-331 regulation. They have copper winding on magnetic core structure with tinned copper lead terminals. Depending on inductance value core is either phenolic material, iron powder or ferrite.

FEATURES

- NF C 93-331 LNZ
- GAM-T-1 lists
- Accurate dimensions
- Superior moisture protection
- Flame retardant coating
- High reliability version on request

DIMENSIONS in millimeters

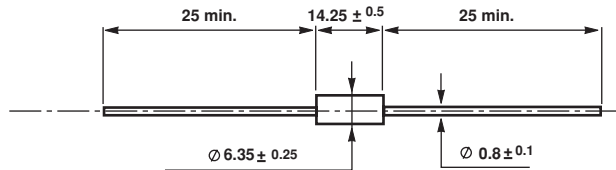

ELECTRICAL SPECIFICATIONS	
Inductance Range	1µH to 8200µH
Tolerance On Request	± 10% 1µH < L ≤ 8200µH ± 5% 1µH < L ≤ 1000µH
Maximum Voltage	500VRMS
Power Rating	500mW at + 70°C

MECHANICAL SPECIFICATIONS

Coating flame retardant
molded epoxy

Terminals tinned copper

Weight 2.7g

ENVIRONMENTAL SPECIFICATIONS

Operating Temperature Range + 70°C

Temperature Limits - 55°C + 125°C



Molded Inductors, Axial Leads,
High Frequency and Noise Suppression Applications

Vishay Aztronic

TR025 INDUCTORS - STANDARD VALUES						
INDUCTANCE VALUE μH	TOLERANCE %	Q MIN.	TEST FREQUENCY MHz	DCR MAX. Ω	SRF MIN. MHz	I MAX. mA
1	$\pm 10\%$	65	25	0.14	200	1900
1.2		40	7.9	0.19	180	1640
1.5				0.28	160	1340
1.8				0.37	150	1160
2.2				0.50	135	1000
2.7				0.65	120	875
3.3				1	105	710
3.9		↓		1.2	100	645
4.7		40		1.8	90	530
5.6		35		0.13	55	1960
6.8				0.20	50	1580
8.2		↓	↓	0.22	44	1510
10		35	7.9	0.26	42	1380
12		45	2.5	0.45	34	1060
15		45		0.52	32	980
18		50		0.70	28	840
22		60		1	24	705
27		60		1.3	22	620
33		60		1.5	20	575
39		70		2	16	500
47		100		2.2	18	475
56		↓		2.3	16	465
68		↓		3	14	405
82		100	↓	3.5	12.5	375
100		95	2.5	3.8	11	365
120		90	0.79	4.2	10	345
150		75		5	8.3	315
180		80		5.3	6	305
220		80		5.9	5.5	290
270		80		6.6	5	275
330		75		7.2	4.2	260
390		75		8.6	3.9	240
470		80		9	3.6	235
560		80		9.7	3.4	225
680		75		10	3.1	220
820		70	↓	12	2.6	200
1000		75	0.79	15	2.6	180
1200		60	0.25	18	2.3	165
1500		70		21	2.1	150
1800		70		23	2	145
2200		75		26	1.7	135
2700		75		33	1.7	120
3300		65		39	1.2	110
3900		65		44	1	105
4700		65		64	0.9	85
5600		65		66	0.85	85
6800		60	↓	70	0.80	82
8200	$\pm 10\%$	70	0.25	72	0.75	80

PACKAGING
Standard: tape packaging
250 pieces tape in box "Ammopack"
500 pieces tape and reel.

MARKING
Standard: Print marked-manufacturer, inductance value, tolerance, or 4 color bands.

ORDERING INFORMATION					
TR SERIES	025 STYLE	220 μH INDUCTANCE VALUE	$\pm 10\%$ TOLERANCE $\pm 10\%$ $\pm 5\%$	R PACKAGING R: tape and reel B: tape in box "Ammopack"	OPTIONAL COLOR BANDS MARKING

Molded Inductors, Axial Leads



These inductors conform to NFC 93-331 regulation. They have copper winding on magnetic core structure with tinned copper lead terminals. Depending on inductance value core is either phenolic material, iron powder or ferrite.

FEATURES

- NF C 93-331
- Accurate dimensions
- Superior moisture protection
- Flame retardant coating
- High reliability version on request

DIMENSIONS in millimeters

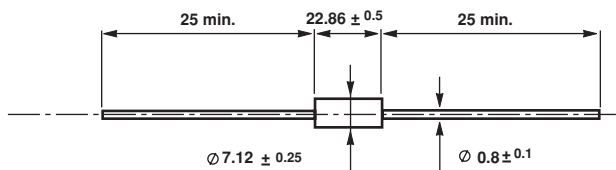

ELECTRICAL SPECIFICATIONS	
Inductance Range	1.2µH to 1000µH
Tolerance On Request	± 10% standard ± 5% 1µH < L ≤ 1000µH ± 2% 1µH < L ≤ 1000µH
Maximum Voltage	500VRMS
Power Rating	750mW at + 70°C

MECHANICAL SPECIFICATIONS

Coating flame retardant
molded epoxy

Terminals tinned copper

Weight 3.5g

ENVIRONMENTAL SPECIFICATIONS

Operating Temperature Range + 70°C

Temperature Limits - 55°C + 125°C



TR026 INDUCTORS - STANDARD VALUES						
INDUCTANCE VALUE μH	TOLERANCE %	Q MIN.	TEST FREQUENCY MHz	DCR MAX. Ω	SRF MIN. MHz	I MAX. mA
1.2	$\pm 10\%$	60	7.9	0.075	170	3150
1.5				0.090	160	2850
1.8				0.135	140	2350
2.2				0.160	125	2170
2.7				0.220	115	1850
3.3				0.330	100	1500
3.9				0.450	95	1290
4.7				0.560	90	1160
5.6				0.745	80	1005
6.8				1.05	75	845
8.2		↓	↓	1.40	68	720
10		60	7.9	1.90	60	630
12		40	2.5	2.65	53	530
15		40		3.25	50	480
18		40		4.15	45	425
22		50		0.295	25	1600
27		60		0.32	26	1530
33		60		0.45	24	1290
39		60		0.65	22	1070
47		70		0.85	20	940
56		70		1.1	18	825
68		80		1.6	16	685
82		80	↓	2	15	610
100		85	2.5	2.5	14	545
120		85	0.79	3.7	13	450
150		95		4.2	11	420
180		95		4.5	10	405
220		95		5	9	385
270		95		6.5	8	340
330		85		7.5	7.4	315
390		75		8.5	7	295
470		80		11.5	6.8	255
570		80		13.5	6.5	235
680		75		15.2	5.8	220
820	↓	80	↓	22	5	180
1000	$\pm 10\%$	80	0.79	25	4.7	170

PACKAGING

Standard: tape packaging
 250 pieces tape in box "Ammopack"
 500 pieces tape and reel.

MARKING

Standard: Print marked-manufacturer, inductance value, tolerance, or 4 color bands.

ORDERING INFORMATION

TR SERIES	026 STYLE	82 μH INDUCTANCE VALUE	$\pm 10\%$ TOLERANCE $\pm 10\%$ $\pm 5\%$	R PACKAGING R: tape and reel B: tape in box "Ammopack"	OPTIONAL COLOR BANDS MARKING
-----------	-----------	-----------------------------------	---	--	------------------------------

Molded Shielded Inductors, Axial Leads, High Frequency and Noise Suppression Applications

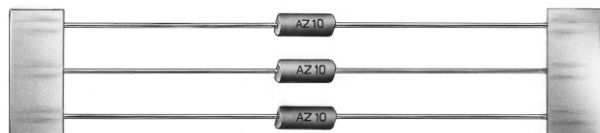

These inductors have copper winding on magnetic core structure with tinned copper lead terminals. Depending on inductance value core is either phenolic material, iron powder or ferrite.

FEATURES

- LNZ
- GAM-T-1
- Accurate dimensions
- Magnetic shielded
- High reliability version on request

DIMENSIONS in millimeters

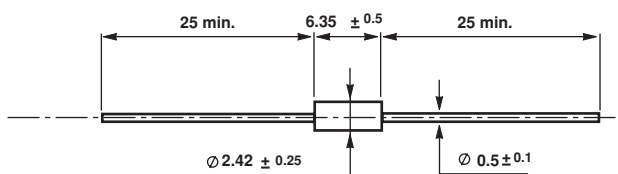

ELECTRICAL SPECIFICATIONS	
Inductance Range	0.1µH to 47µH
Tolerance	± 10% standard
Maximum Voltage	100VRMS
Power Rating	180mW at + 70°C

MECHANICAL SPECIFICATIONS

Coating molded epoxy compound
 Terminals tinned copper
 Weight 0.5g

ENVIRONMENTAL SPECIFICATIONS

Operating Temperature Range + 70°C
 Temperature Limits - 55°C + 125°C



TRB021 INDUCTORS - STANDARD VALUES						
INDUCTANCE VALUE μH	TOLERANCE %	Q MIN.	TEST FREQUENCY MHz	DCR MAX. Ω	SRF MIN. MHz	I MAX. mA
0.10	$\pm 10\%$	30	25	0.10	200	1340
0.12				0.13		1175
0.15				0.15		1100
0.18				0.20		945
0.22				0.25		850
0.27				0.28		800
0.33				0.30		775
0.39				0.32		750
0.47				0.35		720
0.56				0.50	200	600
0.68				0.52	195	590
0.82				0.65	190	525
1			25	0.70	180	510
1.2		30	7.9	0.22	120	905
1.5				0.25	100	850
1.8				0.30	95	775
2.2				0.35	80	720
2.7				0.44	80	645
3.3				0.50	75	600
3.9		45		0.55	65	570
4.7				0.85	62	460
5.6				1.15	50	395
6.8				1.70	45	325
8.2				1.90	43	305
10			7.9	2.10	43	290
12			2.5	2.20	35	285
15				3	34	245
18				1.80	32	315
22				1.90	26	305
27				2	25	300
33				2.10	24	285
39				2.45	22	270
47	$\pm 10\%$	45	2.5	2.80	20	255

PACKAGING

Standard: tape packaging
250 pieces tape in box "Ammopack"
500 pieces tape and reel.

MARKING

Standard: Print marked-manufacturer, inductance value, tolerance, or 4 color bands.

ORDERING INFORMATION

TRB SERIES	021 STYLE	1.2 μH INDUCTANCE VALUE	$\pm 10\%$ TOLERANCE $\pm 10\%$ $\pm 5\%$	R PACKAGING R: tape and reel B: tape in box "Ammopack"	OPTIONAL COLOR BANDS MARKING
------------	-----------	------------------------------------	---	--	------------------------------

Molded Shielded Inductors, Axial Leads, High Frequency and Noise Suppression Applications

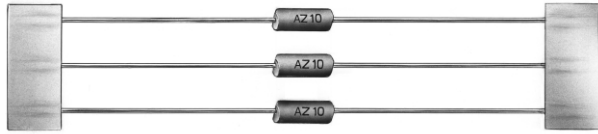

FEATURES

- LNZ
- GAM-T-1 lists
- These inductors have copper winding on magnetic core structure with tinned copper lead terminals
- Depending on inductance value core is either phenolic material, iron powder or ferrite
- Shielding gives a 3% coupling limitation between two inductors

DIMENSIONS in millimeters

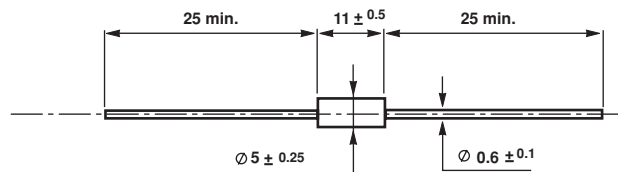

ELECTRICAL SPECIFICATIONS	
Inductance Range	0.1µH to 1200µH
Tolerance	± 10% standard
Maximum Voltage	500VRMS
Power Rating	300mW at + 70°C

MECHANICAL SPECIFICATIONS

Coating	molded epoxy compound
Terminals	tinned copper
Weight	1.3g

ENVIRONMENTAL SPECIFICATIONS

Operating Temperature Range	+ 70°C
Temperature Limits	- 55°C + 125°C



Molded Shielded Inductors, Axial Leads,
High Frequency and Noise Suppression Applications

Vishay Aztronic

TRB023 INDUCTORS - STANDARD VALUES						
INDUCTANCE VALUE μH	TOLERANCE %	Q MIN.	TEST FREQUENCY MHz	DCR MAX. Ω	SRF MIN. MHz	I MAX. mA
0.10	$\pm 10\%$	50	25	0.008	250	4300
0.12				0.010		3880
0.15				0.025		3440
0.18				0.030		3160
0.22				0.036		2880
0.27		50		0.045		2680
0.33		45		0.065		2110
0.39				0.075	250	2000
0.47				0.10	230	1730
0.56				0.13	220	1620
0.68				0.20	195	1220
0.82				0.26	180	1070
1			25	0.06	145	2210
1.2			7.9	0.08	135	1930
1.5				0.10	118	1730
1.8				0.12	110	1580
2.2				0.14	100	1460
2.7				0.16	85	1360
3.3				0.22	75	1160
3.9				0.25	70	1090
4.7				0.30	63	1000
5.6				0.62	58	755
6.8				0.70	54	655
8.2				0.82	48	605
10		45	7.9	0.90	45	575
12		50	2.5	0.85	40	560
15				0.72	36	545
18				0.82	32	605
22				0.96	28	680
27				1.1	25	620
33				1.2	22	600
39				1.8	20	408
47				2	18	386
56				2.2	17	362
68				2.5	16	348
82		50		3.6	11	290
100		45	2.5	3	10	300
120		45	0.79	3.5	9	290
150		50		4.1	8	270
180		50		4.4	6.5	260
220		55		4.9	5.2	245
270		55		6.4	5	215
330		50		7.4	4.8	205
390		50		8	4.3	195
470		65		12	4	155
560		60		13.8	3.5	145
680		55		16	3.3	140
820		50		16.5	3.1	135
1000		45	0.79	23	2.9	115
1200	$\pm 10\%$	45	0.25	27	2.5	110

PACKAGING
Standard: tape packaging
250 pieces tape in box "Ammopack"
500 pieces tape and reel.

MARKING
Standard: Print marked-manufacturer, inductance value, tolerance, or 4 color bands.

ORDERING INFORMATION					
TRB SERIES	023 STYLE	270μH INDUCTANCE VALUE	$\pm 10\%$ TOLERANCE	B PACKAGING	OPTIONAL COLOR BANDS MARKING
			$\pm 10\%$	R: tape and reel B: tape in box "Ammopack"	

Current Chokes, Axial Leads Noise Suppression Applications

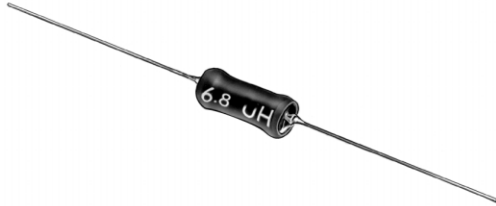

FEATURES

- These Inductors have copper winding on a bobbin with axial lead terminals
- Protection by polyolefin flame retardant sleeve
- Cylindrical shape allows use in automatic cabling machines use
- This inductor series is specially designed for power supply filtering

DIMENSIONS in millimeters

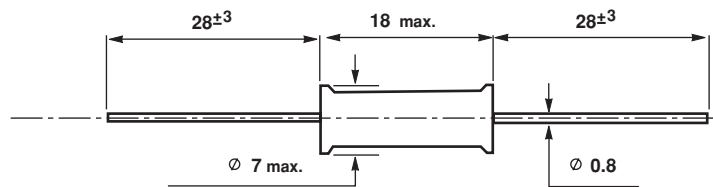

ELECTRICAL SPECIFICATIONS	
Inductance Range	1µH to 18000µH
Tolerance	± 20%
Maximum Voltage	500VRMS
Measuring Conditions	U = 100mVRMS

MECHANICAL SPECIFICATIONS

Coating	thermo sleeve on request UL version
Terminals	tinned copper
Weight	4g

ENVIRONMENTAL SPECIFICATIONS

Operating Temperature Range	+ 70°C
Temperature Limits	- 55°C + 125°C



IG70 INDUCTORS - STANDARD VALUES				
INDUCTANCE VALUE μH IDC = 0	TOLERANCE %	TEST FREQUENCY	DCR MAX. Ω	I MAX. A
1	$\pm 20\%$	1 kHz	0.009	5.3
1.2			0.010	5
1.5			0.011	4.8
1.8			0.012	4.6
2.2			0.013	4.4
2.7			0.014	4.2
3.3			0.016	4
3.9			0.017	3.8
4.7			0.022	3.4
5.6			0.024	3.2
6.8			0.026	3.1
8.2			0.028	3
10			0.033	2.8
12			0.037	2.6
15			0.040	2.5
18			0.044	2.4
22			0.060	2.2
27			0.070	1.9
33			0.075	1.8
39			0.084	1.7
47			0.104	1.6
56			0.130	1.4
68			0.145	1.3
82			0.152	1.3
100			0.208	1.1
120			0.283	0.94
150			0.330	0.87
180			0.362	0.83
220			0.505	0.70
270			0.557	0.67
330			0.650	0.62
390			0.770	0.57
470			1.03	0.49
560			1.14	0.47
680			1.50	0.41
820			1.98	0.36
1000			2.3	0.33
1200			2.55	0.31
1500			3	0.29
1800			4	0.25
2200			4.40	0.24
2700			5.80	0.21
3300			6.56	0.2
3900			8.63	0.17
4700			10.1	0.16
5600			11.2	0.15
6800			15	0.13
8200			20.8	0.11
10000			23.4	0.1
12000			26	0.1
16000			36	0.08
18000	$\pm 20\%$	1 kHz	40	0.08

PACKAGING
500 pieces tape and reel.

MARKING
Print marked: manufacturer, series and style, inductance value, date code.

ORDERING INFORMATION				
IG	70	3900 μH	$\pm 20\%$	R
SERIES	STYLE	INDUCTANCE VALUE	TOLERANCE	PACKAGING
				R: tape and reel

Current Chokes, Axial Leads Noise Suppression Applications

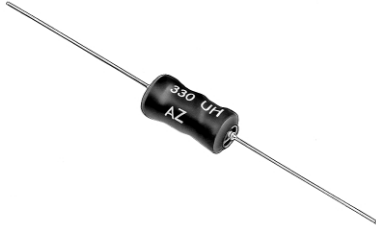

FEATURES

- These Inductors have copper winding on a bobbin with axial lead terminals
- Protection by polyolefin, flame retardant sleeve
- Cylindrical shape allows use in automatic cabling machines
- This inductor series is specially designed for power supply filtering

DIMENSIONS in millimeters

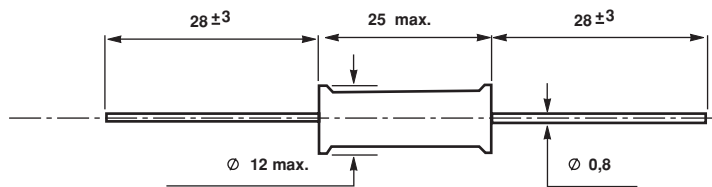

ELECTRICAL SPECIFICATIONS	
Inductance Range	3.9µH to 100000µH
Tolerance	± 20%
Maximum Voltage	500VRMS
Measuring Conditions	U = 100mVRMS

MECHANICAL SPECIFICATIONS

Coating thermo sleeve
on request UL version

Terminals tinned copper

Weight 8g

ENVIRONMENTAL SPECIFICATIONS

Operating Temperature Range + 70°C

Temperature Limits - 55°C + 125°C



IG120 INDUCTORS - STANDARD VALUES				
INDUCTANCE VALUE μH IDC = 0	TOLERANCE %	TEST FREQUENCY	DCR MAX. Ω	I MAX. A
3.9	± 20%	1 kHz	0.007	4
4.7			0.008	
5.6			0.011	
6.8			0.011	
8.2			0.013	
10			0.016	
12			0.018	
15			0.020	
18			0.022	
22			0.024	
27			0.025	
33			0.028	↓
39			0.031	4
47			0.034	3.2
56			0.043	2.5
68			0.059	2
82			0.066	1.8
100			0.084	1.6
120			0.113	
150			0.129	
180			0.150	
220			0.162	
270			0.226	
330			0.257	↓
390			0.288	1.6
470			0.393	1.2
560			0.504	1
680			0.570	1
820			0.643	0.8
1000			0.844	0.8
1200			0.977	0.8
1500			1.18	0.6
1800			1.50	0.6
2200			1.76	0.5
2700			2.13	0.4
3300			2.53	0.4
3900			2.84	0.4
4700			3.79	0.4
5600			4.24	0.32
6800			5.75	0.25
8200			6.44	0.25
10000			7.30	0.25
12000			9.34	0.2
15000			10.7	0.2
18000			14.8	0.16
22000			18	0.13
27000			22.7	0.13
33000			25.7	0.13
39000			29.7	0.1
47000			33.7	0.1
56000			38	0.1
68000			52.8	0.08
82000			67.3	0.07
100000	± 20%	1 kHz	76	0.07

PACKAGING
500 pieces tape and reel.

MARKING

Print marked: manufacturer, series and style, inductance value, date code.

ORDERING INFORMATION				
IG	120	3.3μH	± 20%	R
SERIES	STYLE	INDUCTANCE VALUE	TOLERANCE	PACKAGING
				R: tape and reel

Inductors, Radial Leads, Commercial Use



FEATURES

- Use of a ferrite bobbin with radial terminal configuration allows a high inductance value in a small size
- CH series inductors are especially designed for power supply filtering

DIMENSIONS in millimeters

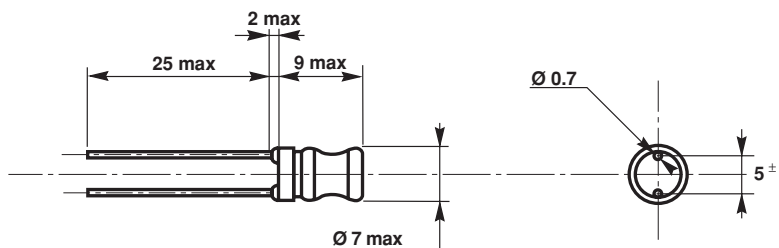

ELECTRICAL SPECIFICATIONS	
Inductance Range	1 μ H to 1000 μ H
Tolerance	$\pm 10\%$
Maximum Voltage	250VRMS

MECHANICAL SPECIFICATIONS

Coating	thermo sleeve
Terminals	tinned copper
Weight	2g

ENVIRONMENTAL SPECIFICATIONS

Operating Temperature Range	+ 70°C
Temperature Limits	- 20°C + 100°C



CH70 INDUCTORS - STANDARD VALUES						
INDUCTANCE VALUE μH IDC = 0	TOLERANCE %	Q MIN.	TEST FREQUENCY MHz	DCR MAX. Ω	SRF MIN. MHz	I MAX. mA
1	± 10%	60	7.96	0.20	105	1030
1.2				0.25	90	980
1.5				0.25	75	920
1.8				0.25	70	880
2.2				0.25	65	830
2.7				0.30	60	790
3.3				0.30	50	750
3.9				0.30	45	720
4.7				0.35	40	670
5.6				0.35	35	640
6.8				0.40	30	620
8.2			↓	0.40	25	590
10			7.96	0.45	20	550
12			2.52	0.50	18	530
15				0.55	17	500
18		↓		0.60	15	480
22		60		0.65	12	460
27		50		0.75	10	430
33				0.85	9	410
39				0.90	8.5	390
47				1	8	370
56				1.2	7.5	350
68				1.3	7	340
82			↓	1.5	6	320
100			2.52	1.6	5.5	305
120			0.796	1.68	5	290
150		↓		1.85	4.6	275
180		50		2.1	4.2	185
220		45		2.3	3.8	175
270				2.75	3.2	165
330		↓		4.68	3	155
390		45		6	2.6	145
470		55		6.50	2.4	140
560				8.50	2.2	135
680				9	2.1	125
820	↓	↓	↓	9.60	1.9	120
1000	± 10%	55	0.796	11.50	1.6	100

PACKAGING
Tape "ammopack" of 1000 pieces

MARKING
Print marked on packaging: inductance value

ORDERING INFORMATION				
CH	70	39μH	± 10%	B
SERIES	STYLE	INDUCTANCE VALUE	STANDARD TOLERANCE	PACKAGING
				B: tape "Ammopack"

Inductors, Radial Leads, Commercial Use



FEATURES

- Use of a ferrite bobbin with radial terminal configuration allows a high inductance value in a small size
- CH series inductors are especially designed for power supply filtering

DIMENSIONS in millimeters

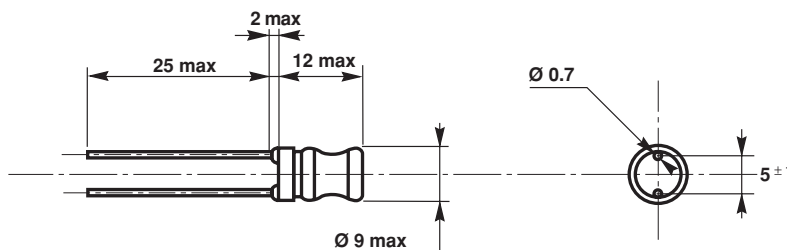

ELECTRICAL SPECIFICATIONS	
Inductance Range	100 μ H to 100000 μ H
Tolerance	$\pm 10\%$
Maximum Voltage	250VRMS

MECHANICAL SPECIFICATIONS

Coating	thermo sleeve
Terminals	tinned copper
Weight	3g

ENVIRONMENTAL SPECIFICATIONS

Operating Temperature Range	+ 70°C
Temperature Limits	- 20°C + 100°C



CH90 INDUCTORS - STANDARD VALUES						
INDUCTANCE VALUE μH IDC = 0	TOLERANCE %	Q MIN.	TEST FREQUENCY MHz	DCR MAX. Ω	SRF MIN. MHz	I MAX. mA
100	± 10%	45	7.96	0.85	4.30	343
120				0.95	4.10	324
150				1.05	3.70	309
180				1.15	3.30	295
220				1.30	2.30	275
270				1.50	2	260
330				1.70	1.95	240
390				1.85	1.85	230
470				2.30	1.57	210
560				2.55	1.50	200
680		↓	↓	2.85	1.40	190
820		45	7.96	3.10	1.32	180
1000		50	0.252	4.10	1.25	160
1200				4.70	1.20	150
1500				5.80	1	130
1800				7.40	0.90	115
2200				8.40	0.80	110
2700				9.60	0.70	95
3300				10.5	0.60	80
3900				12	0.55	70
4700				14	0.50	65
5600				16	0.45	60
6800			↓	18	0.42	55
8200			0.252	24.5	0.40	50
10000			0.0796	32	0.38	45
12000		↓		36	0.36	40
15000		50		38	0.30	35
18000		45		42	0.28	30
22000		45		50	0.26	28
27000		45		62	0.24	26
33000		45		74	0.22	24
39000		40		96	0.20	22
47000		35		102	0.18	20
56000		35		125	0.16	18
68000		35		188	0.14	16
82000	↓	30	↓	240	0.12	14
100000	± 10%	30	0.0796	295	0.10	12

PACKAGING
Tape "ammopack" of 1000 pieces

MARKING
Print marked on packaging: inductance value.

ORDERING INFORMATION				
CH	90	4700μH	± 10%	B
SERIES	STYLE	INDUCTANCE VALUE	STANDARD TOLERANCE	PACKAGING B: tape "Ammopack"

Inductors, Radial Leads, Commercial Use



FEATURES

- Use of a ferrite bobbin with radial terminal configuration allows a high inductance value in a small size
- CH series inductors are especially designed for power supply filtering

DIMENSIONS in millimeters

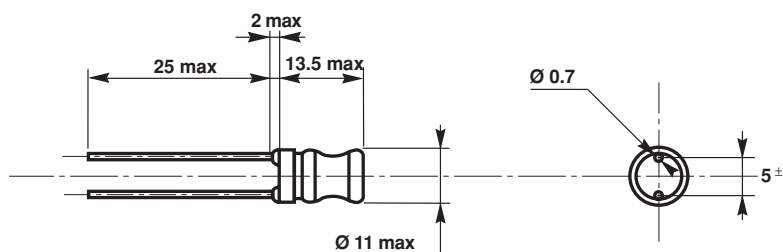

ELECTRICAL SPECIFICATIONS	
Inductance Range	1 μ H to 15000 μ H
Tolerance	\pm 10%
Maximum Voltage	250VRMS

MECHANICAL SPECIFICATIONS

Coating	thermo sleeve
Terminals	tinned copper
Weight	4g

ENVIRONMENTAL SPECIFICATIONS

Operating Temperature Range	+ 70°C
Temperature Limits	- 20°C + 100°C



CH110 INDUCTORS - STANDARD VALUES						
INDUCTANCE VALUE μH IDC = 0	TOLERANCE %	Q MIN.	TEST FREQUENCY MHz	DCR MAX. Ω	SRF MIN. MHz	I MAX. mA
1	± 10%	10	7.96	0.004	85	6400
1.5				0.005	64	5600
2.2				0.006	48	5000
3.3				0.008	36	4500
4.7		↓	↓	0.009	28	4000
6.8		10	7.96	0.012	22	3500
10		20	2.52	0.015	16	3200
15				0.019	12	2800
22				0.026	9.5	2400
33				0.045	7	1800
47			↓	0.056	5.8	1600
68			2.52	0.092	4.7	1300
100			0.796	0.12	3.8	1100
150		↓		0.2	3.1	870
270		20		0.25	2.5	770
330		20		0.42	2	600
470		15	↓	0.51	1.6	540
680		15	0.796	0.79	1.3	440
1000		20	0.252	1.3	1.1	340
1500				1.7	0.82	300
2200				2.9	0.76	230
3300				3.7	0.64	200
4700		↓	↓	5.6	0.54	160
6800		20	0.252	9.4	0.45	130
10000	↓	70	0.0796	12	0.38	110
15000	± 10%	50	0.0796	15	0.29	100

PACKAGING
Tape "ammopack" of 1000 pieces

MARKING
Print marked on packaging: inductance value

ORDERING INFORMATION				
CH	110	680μH	± 10%	B
SERIES	STYLE	INDUCTANCE VALUE	STANDARD TOLERANCE	PACKAGING B: tape "Ammopack"

High Current Toroidal Inductors, EMI/RFI Noise Suppression, Switching Power Supplies And Output Chokes



FEATURES

- SK series inductors have a copper winding on a toroid
- Available with a bare construction or in a case
- Main uses are power supply, filtering or DC/DC converters with frequencies up to 300kHz

DIMENSIONS in millimeters

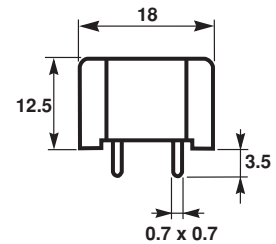
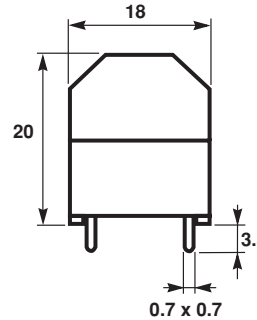
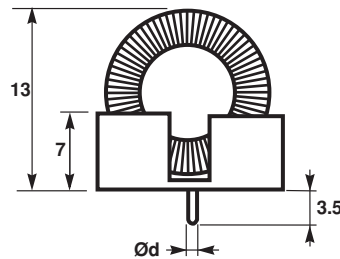
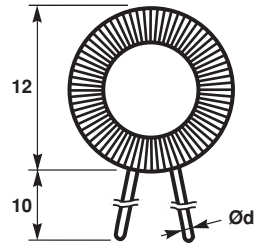
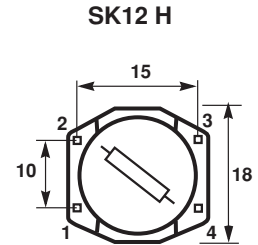
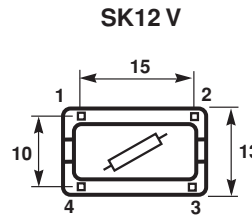
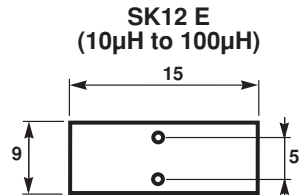
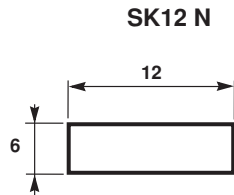

MECHANICAL SPECIFICATIONS

Magnetic Circuit	toroid
Case	plastic
Terminals	wire N and E versions pins: V and H versions

ENVIRONMENTAL SPECIFICATIONS

Operating Temperature Range - 40°C + 125°C

PACKAGING

50 pieces in waffle pack.

INDUCTANCE VALUE VERSUS CURRENT

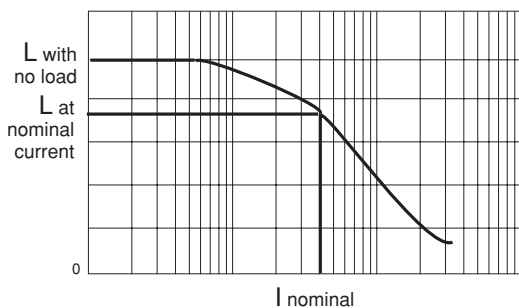

ELECTRICAL SPECIFICATIONS

Tolerance	± 20%
Max. Operating Frequency	300kHz
Maximum Voltage	250VRMS

I MAX. A	L WITH NO LOAD µH	L MIN. AT NOMINAL CURRENT µH	DCR MAX. mΩ	Ø D MAX. (WIRE DIAMETER) N AND E VERSIONS mm
2	10	7	20	0.7
1.5	22	15	38	0.6
1	47	33	84	0.5
0.75	100	70	155	0.4
0.5	220	154	310	0.4
0.315	470	330	875	0.3
0.2	1000	700	1590	0.3

On request: other values or pin configuration.

MARKING (V AND H VERSIONS)

Print marked: manufacturer, series, model, inductance value, nominal current.

ORDERING INFORMATION

SK	12	V	47µH
SERIES	STYLE	VERSION	INDUCTANCE VALUE NO LOAD

High Current Toroidal Inductors, EMI/RFI Noise Suppression, Switching Power Supplies And Output Chokes

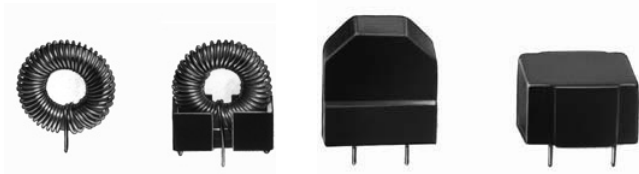
FEATURES

- SK series inductors have a copper winding on a toroid
- Available with a bare construction or in a case
- Main uses are power supply, filtering or DC/DC converters with frequencies up to 300kHz

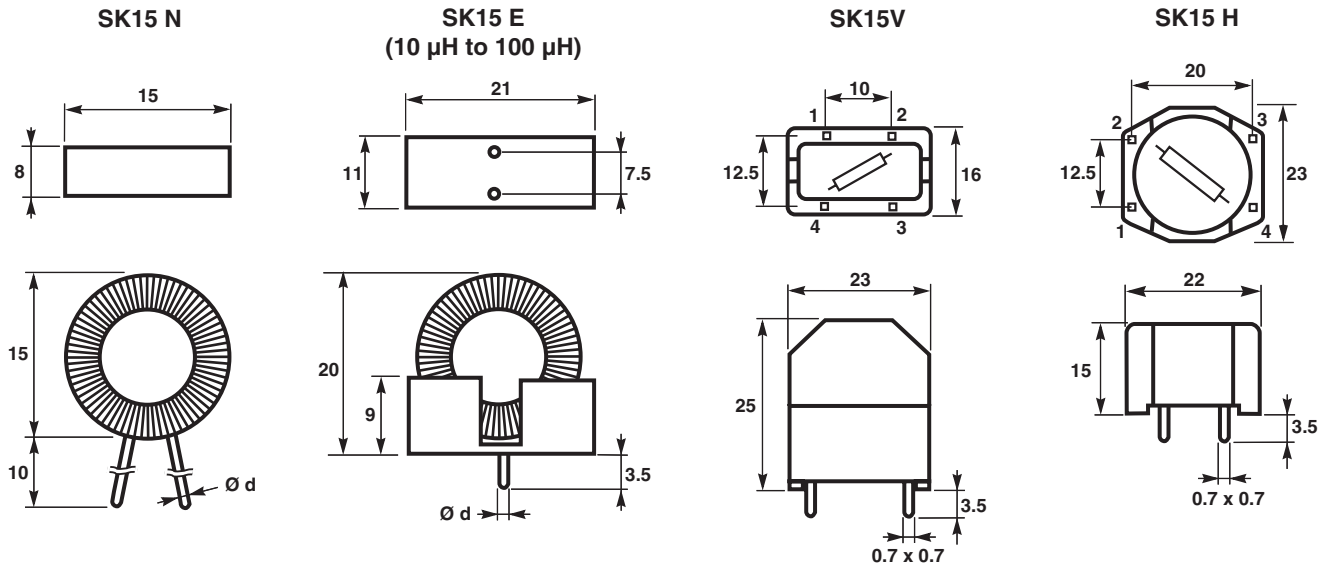
DIMENSIONS in millimeters

MECHANICAL SPECIFICATIONS

Magnetic Circuit	toroid
Case	plastic
Terminals	wire N and E versions pins: V and H versions

ENVIRONMENTAL SPECIFICATIONS

Operating Temperature Range - 40°C + 125°C

PACKAGING

50 pieces in waffle pack.

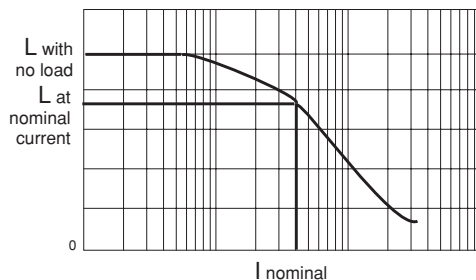
INDUCTANCE VALUE VERSUS CURRENT

ELECTRICAL SPECIFICATIONS

Tolerance	± 20%
Max. Operating Frequency	300kHz
Maximum Voltage	250VRMS

I MAX. A	L WITH NO LOAD μ H	L MIN. AT NOMINAL CURRENT μ H	DCR MAX. m Ω	\varnothing D MAX. (WIRE DIAMETER) N AND E VERSIONS mm
4	10	7	14	09
2.5	22	15	31	0.7
1.6	47	33	72	0.6
1	100	70	163	0.5
0.8	220	154	381	0.4
0.5	470	330	1352	0.3
0.315	1000	700	1978	0.3

On request: other values or pin configuration.

MARKING (V AND H VERSIONS)

Print marked: manufacturer, series, model, inductance value, nominal current.

ORDERING INFORMATION

SK	15	E	47 μ H
SERIES	STYLE	VERSION	INDUCTANCE VALUE NO LOAD

High Current Toroidal Inductors, EMI/RFI Noise Suppression, Switching Power Supplies And Output Chokes



FEATURES

- SK series inductors have a copper winding on a toroid
- Available with a bare construction or in a case
- Main uses are power supply, filtering or DC/DC converters with frequencies up to 300kHz

DIMENSIONS in millimeters

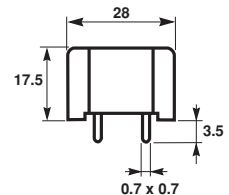
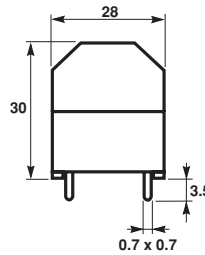
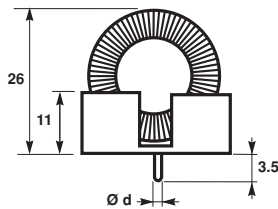
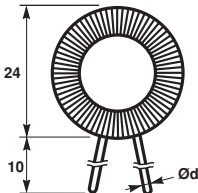
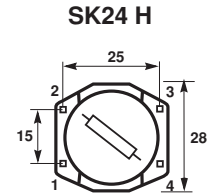
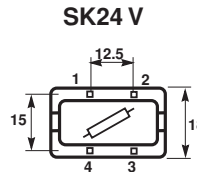
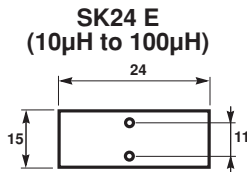
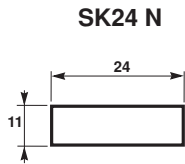

MECHANICAL SPECIFICATIONS

Magnetic Circuit	toroid
Case	plastic
Terminals	wire N, S and E versions pins: V and H versions

ENVIRONMENTAL SPECIFICATIONS

Operating Temperature Range - 40°C + 125°C

PACKAGING

50 pieces in waffle pack.

INDUCTANCE VALUE VERSUS CURRENT

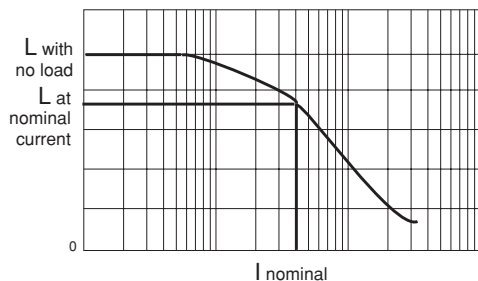

ELECTRICAL SPECIFICATIONS

Tolerance	± 20%
Max. Operating Frequency	300kHz
Maximum Voltage	250VRMS

I MAX. A	L WITH NO LOAD µH	L MIN. AT NOMINAL CURRENT µH	DCR MAX. mΩ	Ø D MAX. (WIRE DIAMETER) N - S - E VERSIONS mm
6	10	7	8	1.2
4	22	15	21	0.9
3	47	33	39	0.8
2	100	70	91	0.7
1.5	220	154	166	0.6
1	470	330	376	0.5
0.7	1000	700	871	0.4

On request: other values or pin configuration.

MARKING (V AND H VERSIONS)

Print marked: manufacturer, series, model, inductance value, nominal current.

ORDERING INFORMATION

SK	24	S	47µH
SERIES	STYLE	VERSION	INDUCTANCE VALUE NO LOAD

High Current Toroidal Inductors, EMI/RFI Noise Suppression, Switching Power Supplies And Output Chokes

FEATURES

- SK series inductors have a copper winding on a toroid
- Available with a bare construction or in a case
- Main uses are power supply, filtering or DC/DC converters with frequencies up to 300kHz

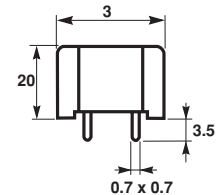
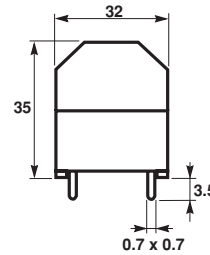
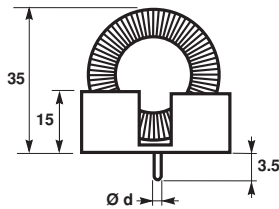
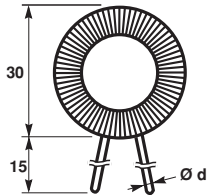
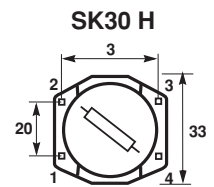
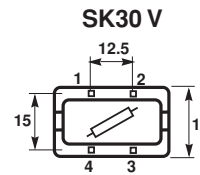
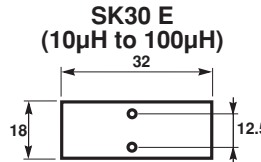
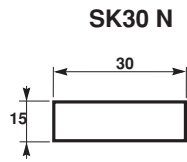
DIMENSIONS in millimeters

MECHANICAL SPECIFICATIONS

Magnetic Circuit	toroid
Case	plastic
Terminals	wire N, S and E versions pins: V and H versions

ENVIRONMENTAL SPECIFICATIONS

Operating Temperature Range - 40°C + 125°C

PACKAGING

50 pieces in waffle pack.

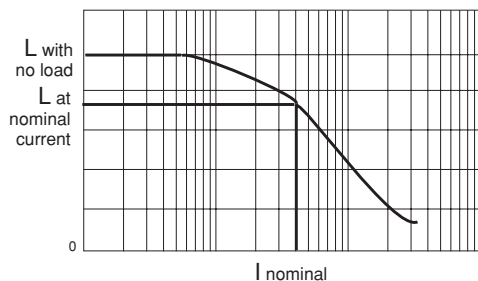
INDUCTANCE VALUE VERSUS CURRENT

ELECTRICAL SPECIFICATIONS

Tolerance	± 20%
Max. Operating Frequency	300kHz
Maximum Voltage	250VRMS

I MAX. A	L WITH NO LOAD μH	L MIN. AT NOMINAL CURRENT μH	DCR MAX. mΩ	Ø D MAX. (WIRE DIAMETER) N - S - E VERSIONS mm
8	10	7	15	1.1
6.3	22	15	30	1
4	47	33	63	0.8
2.5	100	70	149	0.7
1.6	220	154	341	0.6
1.25	470	330	623	0.5
0.8	1000	700	1465	0.4

On request: other values or pin configuration.

MARKING (V AND H VERSIONS)

Print marked: manufacturer, series, model, inductance value, nominal current.

ORDERING INFORMATION

SK	30	V	47μH
SERIES	STYLE	VERSION	INDUCTANCE VALUE NO LOAD

High Current Toroidal Inductors, EMI/RFI Noise Suppression, Switching Power Supplies And Output Chokes



FEATURES

- Copper winding on toroid construction
- Available with a bare construction or in a case
- Main uses are power supply, filtering or DC/DC converters with frequencies up to 300kHz

DIMENSIONS in millimeters
SK40 N

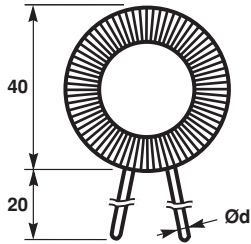
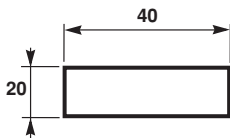

SK40 H

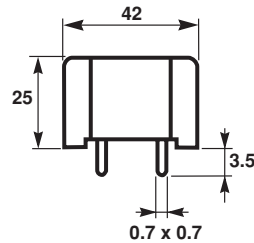
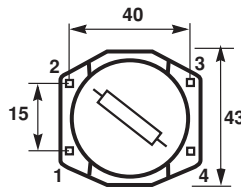

SK40 V

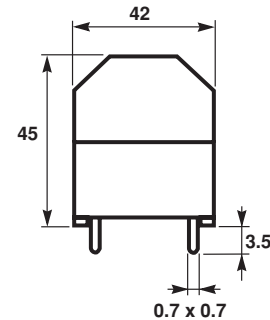
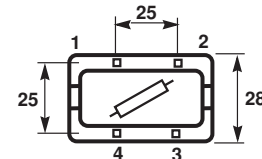

MECHANICAL SPECIFICATIONS

Magnetic Circuit	toroid
Case	plastic
Terminals	wire N and E versions pins: V version

ENVIRONMENTAL SPECIFICATIONS

Operating Temperature Range - 40°C + 125°C

PACKAGING

50 pieces in waffle pack.

INDUCTANCE VALUE VERSUS CURRENT

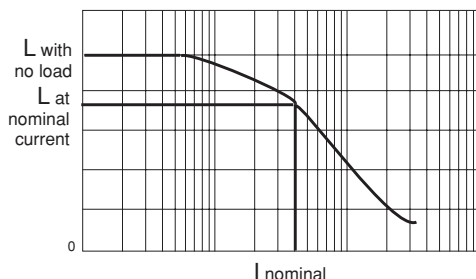

ELECTRICAL SPECIFICATIONS

Tolerance	± 20%
Max. Operating Frequency	300kHz
Maximum Voltage	250VRMS

I MAX. A	L WITH NO LOAD µH	L MIN. AT NOMINAL CURRENT µH	DCR MAX. MΩ	Ø D MAX. (WIRE DIAMETER) N VERSION mm
15	10	7	7	1.4
12	22	15	12	1.2
8	47	33	25	1.1
5.5	100	70	55	0.9
3.5	220	154	104	0.8
2.5	470	330	241	0.7
1.75	1000	700	681	0.5

On request: other values or pin configuration.

MARKING (V VERSION)

Print marked: manufacturer, series, model, inductance value, nominal current.

ORDERING INFORMATION

SK	40	H	47µH
SERIES	STYLE	VERSION	INDUCTANCE VALUE NO LOAD

Common Mode Inductors, Noise Suppression

FEATURES

- VDE 565-2
- Conform to VDE 565-2.
- Copper winding on ferrite toroid in epoxy case
- Phase opposition winding is an excellent filter for assymmetrical (common mode) noise
- Efficiency can be increased with Y-capacitors and X-capacitors to make an EMC filter
- Vertical mounting, style V or horizontal mounting, style H
- Main use is switching power supplies

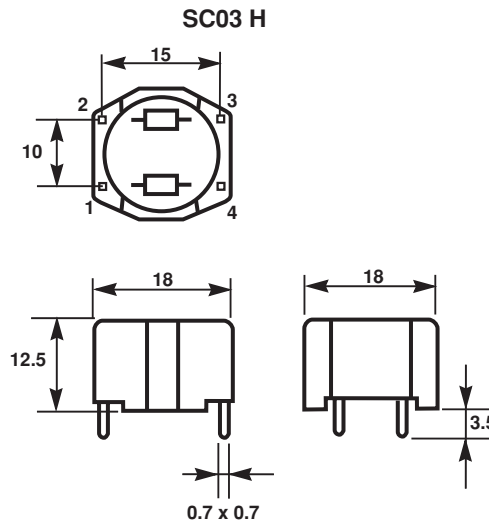
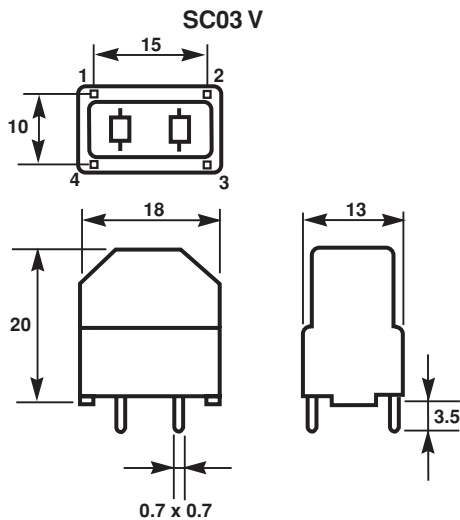
DIMENSIONS in millimeters

**ELECTRICAL
DIAGRAM**

MECHANICAL SPECIFICATIONS

Toroid	ferrite
Case	plastic

ENVIRONMENTAL SPECIFICATIONS

Operating Temperature Range - 40°C + 125°C

PACKAGING

50 pieces in waffle pack.

MARKING

Print marked: manufacturer, series, model, inductance value, nominal current by winding, nominal operating voltage, diagram windings

ELECTRICAL SPECIFICATIONS

Nominal Operating Voltage	250VRMS
Limiting Voltage	1500VRMS 50Hz

NOMINAL CURRENT A	BY WINDING	
	INDUCTANCE mH	DCR MAX. mΩ
0.3	47	4100
0.4	33	2600
0.5	18	1500
0.7	10	600
1.2	6.8	290
1.3	4.7	220
1.5	3.3	180
2	1	90
3.5	0.47	37

Other values on request.

ORDERING INFORMATION

SC	03	V	6.8mH
SERIES	MODEL	VERSION V: vertical H: horizontal	INDUCTANCE VALUE

Common Mode Inductors, Noise Suppression

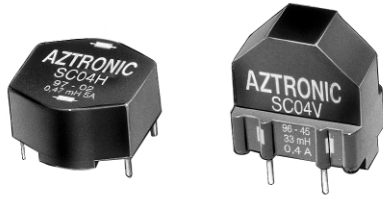

FEATURES

- Conform to VDE 565-2
- Copper winding on ferrite toroid in epoxy case
- Phase opposition winding is an excellent filter for asymmetrical (common mode) noise.
- Efficiency can be increased with Y-capacitors and X-capacitors to make an EMC filter.
- Vertical mounting, style V or horizontal mounting style H
- Main use is switching power supplies

DIMENSIONS in millimeters

SC04 V

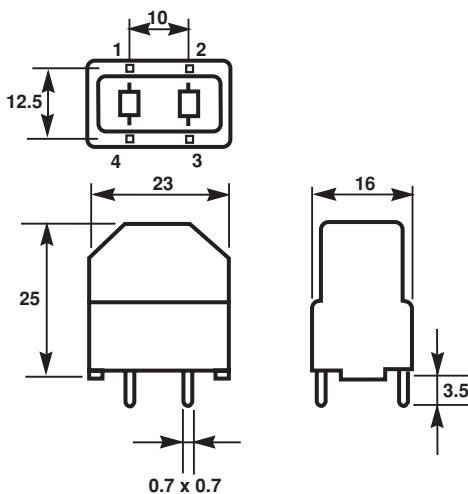

SC04 H

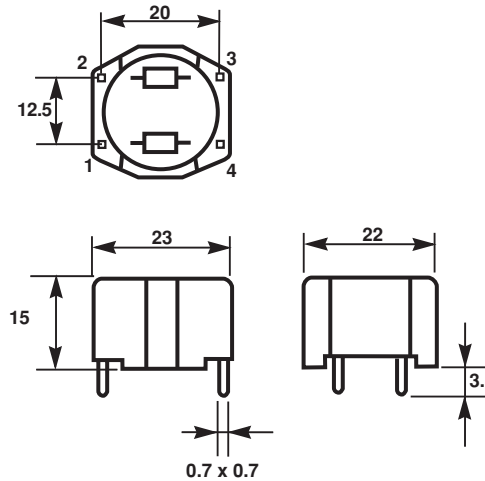

ELECTRICAL DIAGRAM

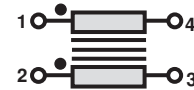

MECHANICAL SPECIFICATIONS

Toroid ferrite
Case plastic

ENVIRONMENTAL SPECIFICATIONS

Operating Temperature Range - 40°C + 125°C

PACKAGING

50 pieces in waffle pack.

MARKING

Print marked: manufacturer, series, model, inductance value, nominal current by winding, nominal operating voltage, diagram windings

ELECTRICAL SPECIFICATIONS

Nominal Operating Voltage 250VRMS
Limiting Voltage 1500VRMS 50Hz

NOMINAL CURRENT A	BY WINDING	
	INDUCTANCE mH	DCR MAX. mΩ
0.3	47	2600
0.4	33	1800
0.7	18	1000
1	10	540
1.1	6.8	450
1.3	4.7	320
1.7	3.3	200
3	1.0	56
5	0.47	30

Other values on request.

ORDERING INFORMATION

SC	04	V	33mH
SERIES	MODEL	VERSION V: vertical H: horizontal	INDUCTANCE VALUE

Common Mode Inductors, Noise Suppression

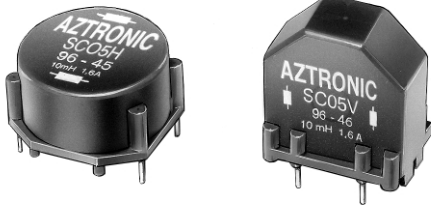
FEATURES

- Conform to VDE 565-2
- Copper winding on ferrite toroid in epoxy case
- Phase opposition winding is an excellent filter for asymmetrical (common mode) noise.
- Efficiency can be increased with Y-capacitors and X-capacitors to make an EMC filter.
- Vertical mounting, style V or horizontal mounting, style H
- Main use is switching power supplies

DIMENSIONS in millimeters

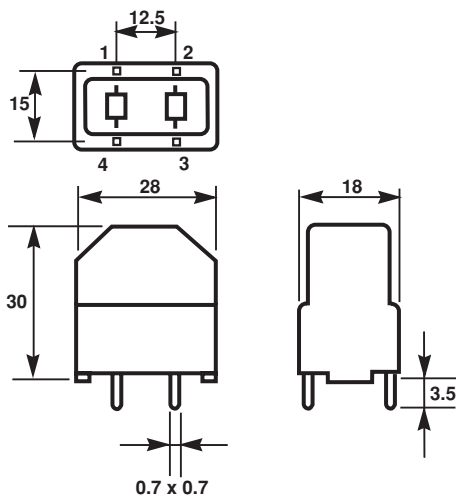
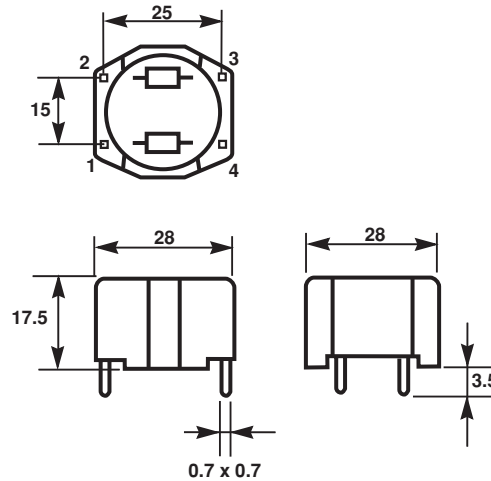
SC05 V

SC05 H

ELECTRICAL DIAGRAM

MECHANICAL SPECIFICATIONS

Toroid	ferrite
Case	plastic

ENVIRONMENTAL SPECIFICATIONS

Operating Temperature Range - 40°C + 125°C

PACKAGING

50 pieces in waffle pack.

MARKING

Print marked: manufacturer, series, model, inductance value, nominal current by winding, nominal operating voltage, diagram windings

ELECTRICAL SPECIFICATIONS

Nominal Operating Voltage	250VRMS
Limiting Voltage	1500VRMS 50Hz

NOMINAL CURRENT A	BY WINDING	
	INDUCTANCE mH	DCR MAX. mΩ
0.6	47	1100
0.6	33	900
0.7	18	800
1.6	10	210
2	6.8	130
2.1	4.7	100
2.8	3.3	70
3.2	1	50
4.1	0.47	35

Other values on request.

ORDERING INFORMATION

SC	05	V	47mH
SERIES	MODEL	VERSION V: vertical H: horizontal	INDUCTANCE VALUE

Common Mode Inductors, Noise Suppression



FEATURES

- Conform to VDE 565-2
- Copper winding on ferrite toroid in epoxy case
- Phase opposition winding is an excellent filter for asymmetrical (common mode) noise.
- Efficiency can be increased with Y-capacitors and X-capacitors to make an EMC filter.
- Vertical mounting, style V or horizontal mounting style H
- Main use is switching power supplies

DIMENSIONS in millimeters

SC06 V

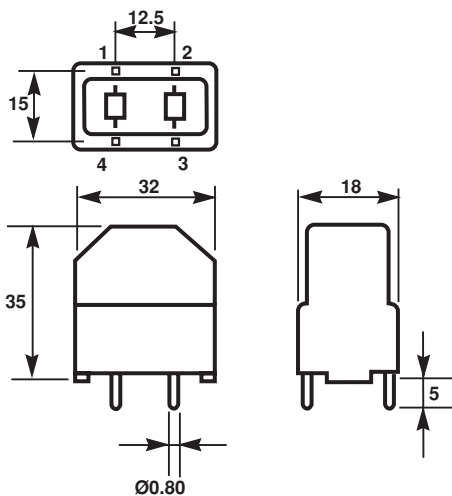

SC06 H

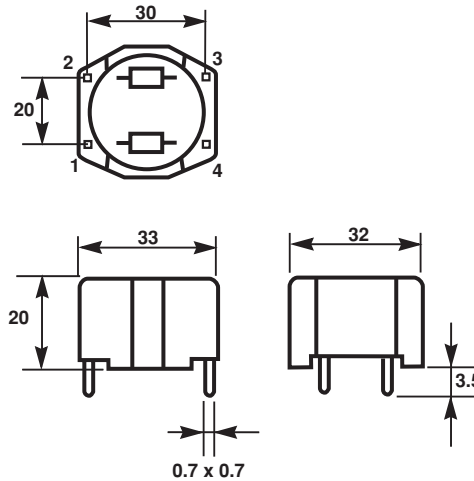

ELECTRICAL DIAGRAM



MECHANICAL SPECIFICATIONS

Toroid ferrite
Case plastic

ENVIRONMENTAL SPECIFICATIONS

Operating Temperature Range - 40°C + 125°C

PACKAGING

50 pieces in waffle pack.

MARKING

Print marked: manufacturer, series, model, inductance value, nominal current by winding, nominal operating voltage, diagram windings

ELECTRICAL SPECIFICATIONS

Nominal Operating Voltage 250VRMS
Limiting Voltage 1500VRMS 50Hz

NOMINAL CURRENT A	BY WINDING	
	INDUCTANCE mH	DCR MAX. mΩ
0.7	47	1050
1	33	600
1.4	18	350
1.8	10	150
2.2	6.8	100
3	4.7	85
4	3.3	70
5	1	55
6	0.47	40

Other values on request.

ORDERING INFORMATION

SC	06	V	10mH
SERIES	MODEL	VERSION V: vertical H: horizontal	INDUCTANCE VALUE



Data and Voice Access Transformers

Impedance, Wideband or Pulse
Transformers

•
Signal/Flyback or DC/DC Microconverters

•
Toroidal Filter and Common Mode Styles

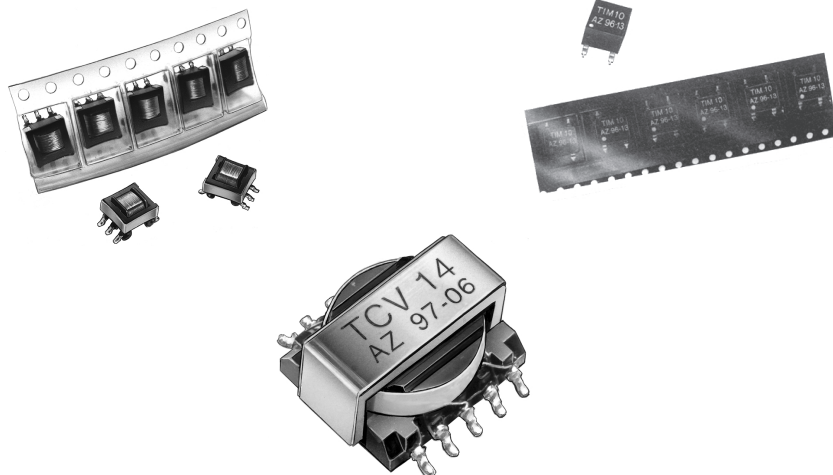

Model Numbers

TLB51	54
TIM 10, 20, 40	55
TIR6	56
TCV5	57
TCV11	58
TCV14	59
TCV14U1	60
TU2091	61
TLP13-600, -300, -150 ..	62
TA32	63
TA34	64
TA34M	65
TA90	66

Wideband Transformers

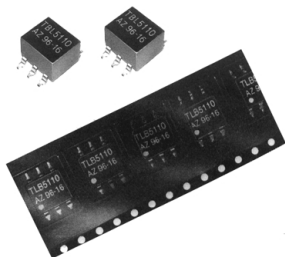

DIMENSIONS in millimeters

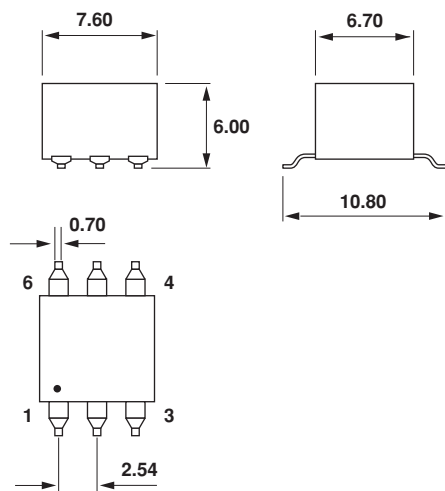

MECHANICAL SPECIFICATIONS

Case UL 94 V0
 Unit Weight 1g

CLIMATIC SPECIFICATIONS

Temperature Range: Shelf - 55°C + 85°C
 Working - 30°C + 75°C

MARKING

Print marked: series, model, manufacturer, manufacturing date (code), pin 1.

BANDWIDTH

TLB 5110

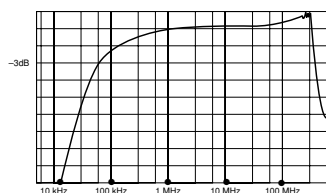

TLB 5115

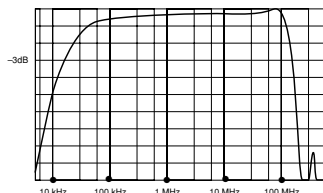

TLB 5125

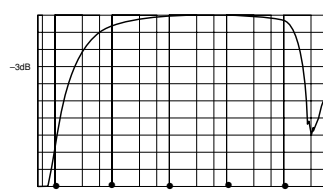

TLB 5140

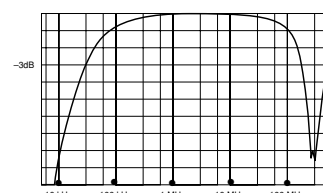

PACKAGING

Tape 24mm width, 12mm pitch.
 Reel 500 pieces: external dia: 325mm
 height: 31mm

FEATURES

- Magnetic circuit is potted in a DAP case, UL 94 V0 approved, which makes the product suitable for reflow soldering
- Can be used from 40kHz to 500MHz with impedance from 50Ω to 600Ω with a low insertion loss

ELECTRICAL DIAGRAM

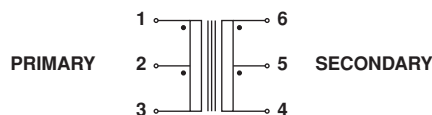

RECOMMENDED SOLDERING PAD

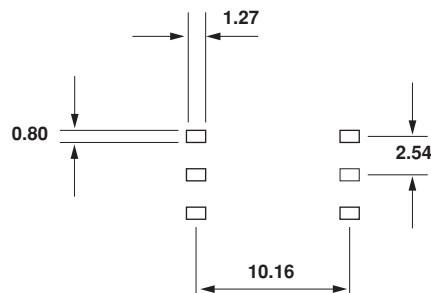

ELECTRICAL SPECIFICATIONS

Input Power 250mW max.
 Max. Current 100mA
 Insulation Voltage 100VRMS
 Frequency Response

	TLB5110	TLB5115	TLB5125	TLB5140
Impedance Ratio	1	1.5	2.5	4
Bandwidth - 3 dB	0.06 to 360MHz	0.015 to 153MHz	0.03 to 190MHz	0.03 to 160MHz

ORDERING INFORMATION

TLB51	10	R
SERIES	MODEL	PACKAGING
		R: tape and reel

Pulse Transformers for General Use

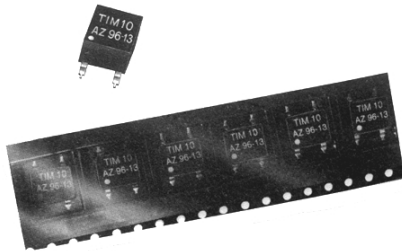

DIMENSIONS in millimeters

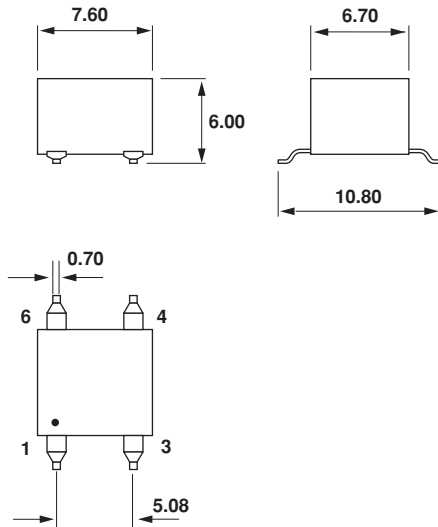

MECHANICAL SPECIFICATIONS

Case	UL 94 V0
Unit Weight	1g

CLIMATIC SPECIFICATIONS

Temperature Range	
Shelf	- 55°C + 85°C
Working	- 30°C + 75°C

PACKAGING

Tape 24mm width, 12mm pitch.
Reel 750 pieces: external dia: 330mm
height: 31mm

MARKING

Print marked: series, model, manufacturer, manufacturing date (code), pin 1.

ORDERING INFORMATION

TIM	10	R
SERIES	MODEL	PACKAGING
		R: tape and reel

FEATURES

- These micro transformers are designed for pulse transmission for frequencies up to 300kHz
- They are used for signal synchronization, power supplies and transistor control
- Available taped and reeled which allows automatic pick and place

ELECTRICAL DIAGRAM

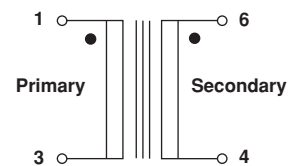

RECOMMENDED SOLDERING PAD

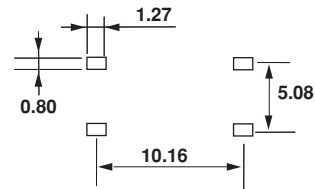

ELECTRICAL SPECIFICATIONS

Maximum Frequency	300kHz
Insulation Resistance	1000VRMS

SERIES AND MODEL	TIM 10	TIM 20	TIM 40
Secondary/Primary Ratio	1	2	4
Primary Inductance ± 25%	30µH	30µH	8.5µH
Primary Resistance ± 20%	140mΩ	300mΩ	160mΩ
Secondary Resistance ± 20%	140mΩ	600mΩ	600mΩ
Primary DC Current max.	50mA	50mA	100mA
Primary Peak Current	200mA	200mA	400mA
ET Factor	3.5Vµs	3.5Vµs	4Vµs

Pulse Transformers



FEATURES

- TIR pulse transformers are general use products
- They can be used for transistor drive switching power supplies or data line isolation
- Stick packaging allows automatic insertion

DIMENSIONS in millimeters

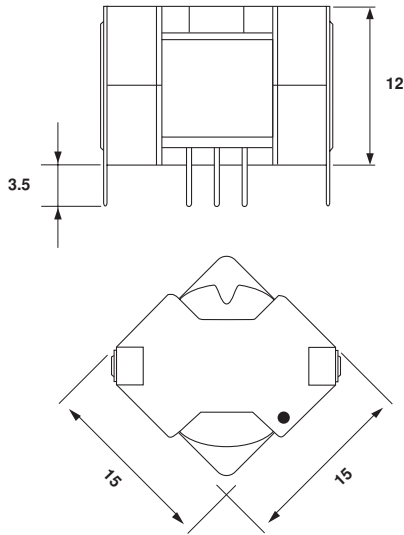

CONFIGURATION (TOP VIEW)

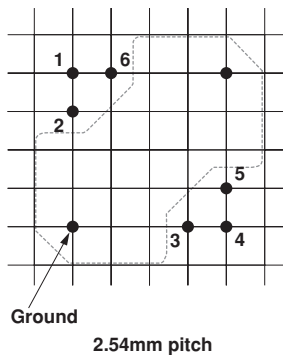

ELECTRICAL DIAGRAM

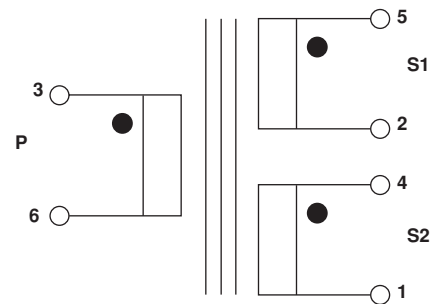

MECHANICAL SPECIFICATIONS

Ferrite RM6 6 pins
 Unit Weight 8g

CLIMATIC SPECIFICATIONS

Temperature Range Shelf -55°C + 85°C
 Operating -30°C + 75°C

PACKAGING

25 pieces in stick.

MARKING

Print marked: manufacturer, series, model, manufacturing date (code), pin 1.

ELECTRICAL SPECIFICATIONS

Dielectric Strength 500VRMS

	TIR6-10	TIR6-20	TIR6-40
Ratio S1/ P = S2/ P	1	2	4
Min. Primary Inductance	1.4H	0.5H	125mH
Resistance RP max.	70Ω	40Ω	20Ω
Resistance RS1 = RS2	83Ω	96Ω	94Ω
Max. Primary current	0.5mA	0.6mA	2mA
Max. Peak Current	75mA	100mA	140mA
ET Factor	1000Vμs	600Vμs	500Vμs

ORDERING INFORMATION

TIR6
 SERIES

10
 MODEL

Microconverter Transformers/Inductors

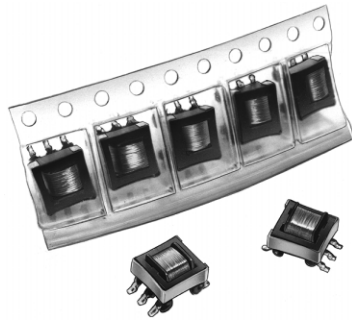

FEATURES

- Adding up one or more secondary to the basic inductor TCV5 allows build up of flyback transformers for micro converters with a power of 0.5W
- Tape and reel packaging allows automatic pick and place

DIMENSIONS in millimeters

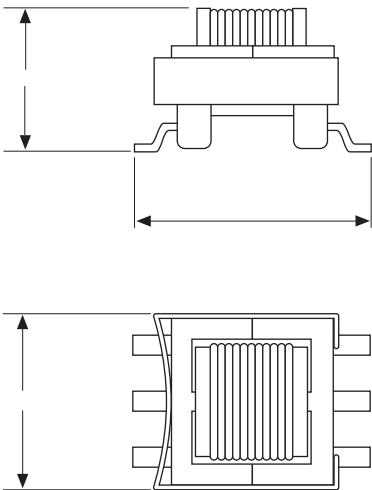

RECOMMENDED SOLDERING PAD

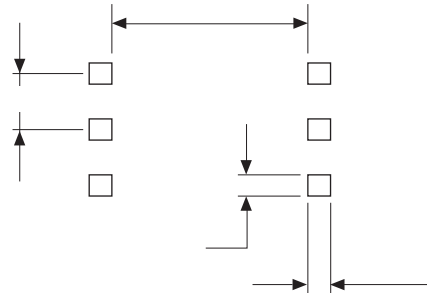

ELECTRICAL DIAGRAM



MECHANICAL SPECIFICATIONS

Ferrite	E5
Unit Weight	SMD frame
Configuration	6 pins 1.85mm pitch

CLIMATIC SPECIFICATIONS

Working Temperature Range - 20°C + 80°C

PACKAGING

500 pieces per reel.
Taped 24mm width, 12mm pitch.

MARKING

Print marked: manufacturer, series, value, manufacturing date (code).

ELECTRICAL SPECIFICATIONS

INDUCTANCE μH ± 20%	DCR MAX Ω	SATURATION* CURRENT A	NOMINAL ** CURRENT A
10	0.19	1.5	0.80
15	0.25	1.2	0.75
22	0.38	1.0	0.60
33	0.60	0.9	0.45
47	0.86	0.7	0.40
68	1.32	0.6	0.30
100	2.04	0.5	0.20
150	2.91	0.4	0.19
220	3.48	0.35	0.18
330	5.52	0.30	0.14
470	8.40	0.25	0.11
680	12.48	0.20	0.10
1000	15.48	0.15	0.08

*DC current which create a 20% loss of inductance value.

**DC current which will create a maximum temperature rise of 30°C when applied at 25°C ambient.

ORDERING INFORMATION

TCV5
SERIES

100μH
INDUCTANCE VALUE

Microconverter Transformers/Inductors

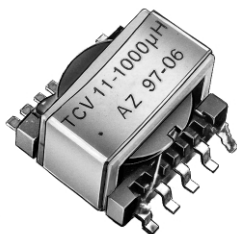

FEATURES

- Adding up one or more secondary to the basic inductor TCV11 allows build up of flyback transformers for micro converters with a power of 6W
- Tape and reel packaging allows automatic pick and place

DIMENSIONS in millimeters

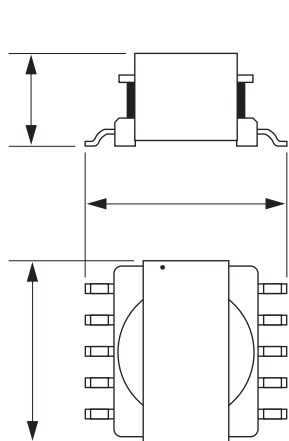

RECOMMENDED SOLDERING PAD

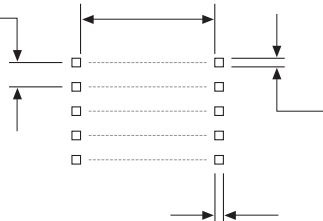

ELECTRICAL DIAGRAM

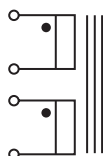

TYPICAL APPLICATIONS

STEP DOWN

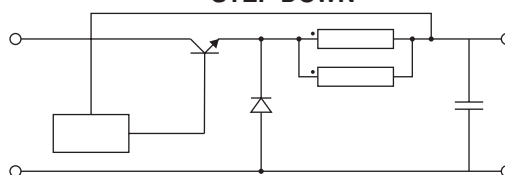

STEP UP

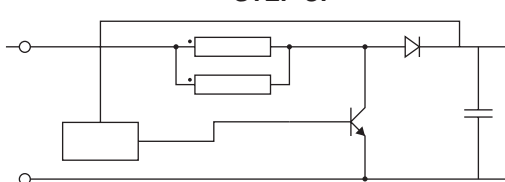

MECHANICAL SPECIFICATIONS

Ferrite	ER11
Case	SMD frame
Configuration	10 pins 2mm pitch

ELECTRICAL SPECIFICATIONS

Insulation Voltage Between Winding	100VRMS
Ratio (1-6)/(5-10)	1/1
Quench Frequency Max	200kHz
Electrical Values	(1-6)/(5-10)

CLIMATIC SPECIFICATIONS

Working Temperature Range - 20°C + 85°C

PACKAGING

600 pieces/reel.
Taped 24mm width, 16mm pitch.

MARKING

Print marked: manufacturer, series, value, manufacturing date (code), pin 1.

ORDERING INFORMATION

TCV11	100µH
SERIES	VALUE

INDUCTANCE µH ± 20%	RCC MAX (Ω)	SATURATION* CURRENT (A)	NOMINAL ** CURRENT (A)
10	0.015	2.00	4.80
22	0.030	1.20	3.80
47	0.055	1.00	3.10
68	0.095	0.80	1.80
100	0.145	0.70	1.60
220	0.265	0.37	1.10
470	0.480	0.30	0.80
680	0.750	0.25	0.50
1000	1.625	0.20	0.40

* DC current which creates a 20% drop of inductance value.
** DC current which will create a maximum temperature rise of 30°C when applied at 25°C ambient.

Microconverter Transformers/Inductors



FEATURES

- Adding up one or more secondary to the basic inductor TCV14 allow build up of flyback transformers for micro converters with a power of 11W
- Tape and reel packaging allows automatic pick and place

DIMENSIONS in millimeters

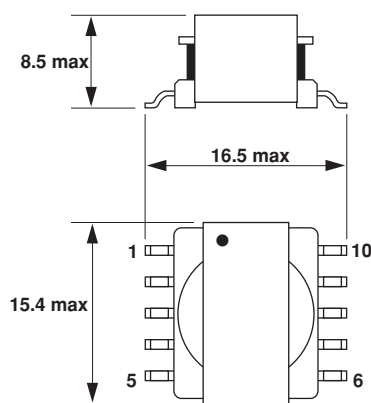

RECOMMENDED SOLDERING PAD

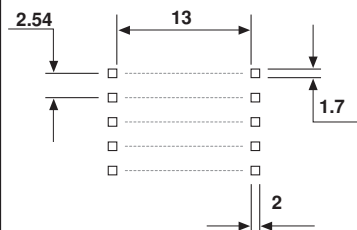

ELECTRICAL DIAGRAM

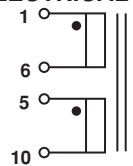

TYPICAL APPLICATIONS STEP DOWN

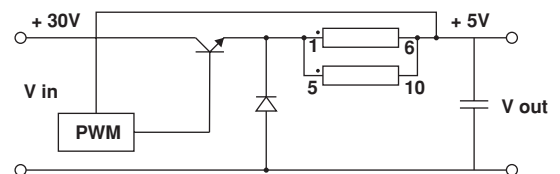

STEP UP

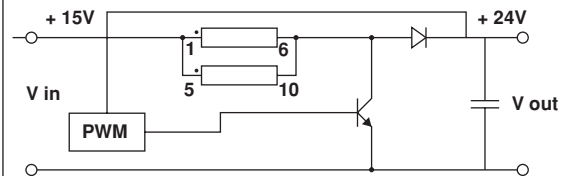

MECHANICAL SPECIFICATIONS

Ferrite	ER14
Case	SMD frame
Configuration	10 pins 2.54mm pitch

ELECTRICAL SPECIFICATIONS

Insulation Voltage Between Winding	100VRMS
Ratio (1-6)/(5-10)	1/1
Quench Frequency Max	200kHz
Electrical Values	(1-6)/(5-10)

CLIMATIC SPECIFICATIONS

Working Temperature Range - 20°C + 85°C

PACKAGING

300 pieces/reel.
Taped 32mm width, 20mm pitch.

MARKING

Print marked: manufacturer, series, value, manufacturing date (code), pin 1.

ORDERING INFORMATION

TCV14	100µH
SERIES	VALUE

INDUCTANCE µH ± 20%	RCC MAX (Ω)	SATURATION* CURRENT (A)	NOMINAL ** CURRENT (A)
10	0.028	2.9	6.9
22	0.072	2.2	3.8
47	0.112	1.9	3.5
68	0.168	1.6	2.6
100	0.254	1.4	2.1
220	0.490	0.9	1.5
470	1.086	0.7	0.9
680	1.920	0.6	0.7
1000	2.400	0.5	0.6

* DC current which creates a 20% loss of inductance value.

** DC current which will create a maximum temperature rise of 30°C when applied at 25°C ambient.

Microconverter Transformers



FEATURES

- TCV14 transformers are designed for 11W flyback microconverters
- They are compatible with standard PWM circuits
- High frequency capability and SMD design offers an excellent power/volume ratio
- Tape and reel packaging allows automatic pick and place

DIMENSIONS in millimeters

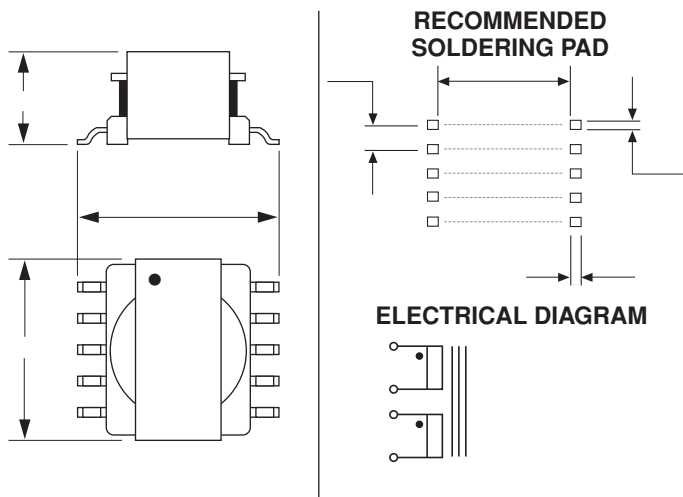

TYPICAL APPLICATIONS

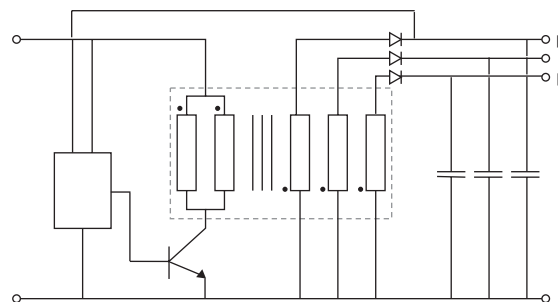

MECHANICAL SPECIFICATIONS

Ferrite	ER14
Case	SMD frame
Configuration	10 pins 2.54mm pitch

CLIMATIC SPECIFICATIONS

Working Temperature Range - 20°C + 85°C

PACKAGING

300 pieces/reel.
Taped 32mm width, 20mm pitch.

ELECTRICAL SPECIFICATIONS

Max. Primary Resistance (1-10//5-6)	0.1Ω
Primary Inductance (1-10//5-6)	14μH ± 20%
Max. Primary DC Current	1.8A
Primary Peak Current	2.4A
Dielectric Strength (1-10/5-6)/(9-2/8-3/7-4)	500VDC
Quench Max. Frequency	200kHz
Max. Power	11W
Max. Leakage Inductance	200nH
Parasitic Capacitance P/S	50pF

MARKING

Print marked: manufacturer, series, application code, manufacturing date (code), pin 1.

ORDERING INFORMATION

TCV14	U1
SERIES	APPLICATION CODE

Winding	(2-9)	(3-8)	(4-7)
Typical Output Voltage	+ 5V	+ 3.3V	+ 12V
Max. Current Output	1A	1A	0.25A
Max. Resistance	0.06Ω	0.04Ω	0.500Ω
Ratio Versus 1-10 // 5-6	1	0.647	2.412

ISDN Transformers



FEATURES

- Ferrite RM style has a compact profile and allows automated production at low cost
- Transformers TU2091 series are used for ISDN transmission 2 wires up to 10km according to 4B3T and 2B1Q regulation

DIMENSIONS in millimeters

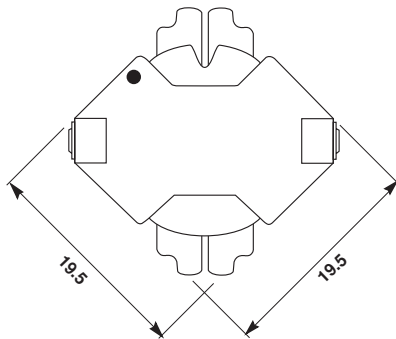
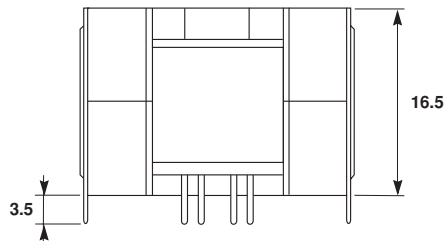

CONFIGURATION (TOP VIEW)

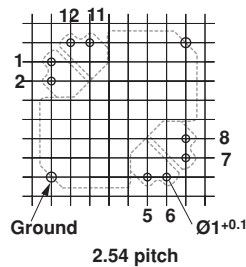

ELECTRICAL DIAGRAM

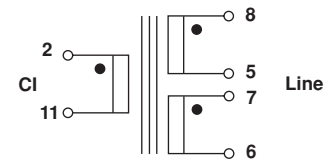

MECHANICAL SPECIFICATIONS

Ferrite	RM8 - 8 pins
Configuration	2.54mm pitch
Unit Weight	20g

CLIMATIC SPECIFICATIONS

Temperature Limits	- 20°C + 85°C
--------------------	---------------

IC COMPATIBILITY

Siemens reference	IECQ PEB 2091
AMD reference	AMD 2091

MARKING

Print marked: manufacturer, series, manufacturing date (code), pin 1.

ELECTRICAL SPECIFICATIONS

Inductance (2-11)	14.5mH ± 10% at 10kHz 100mV
Input/Output Ratio	8-5: 0.8 2-11: 1 7-6: 0.8
Leakage Inductance	< 90µH at 100kHz 100mV
DC Current	60mA max
Maximum Resistance/Winding	8-5: 1.35Ω 2-11: 2.38Ω 7-6: 1.35Ω
Coupling Capacitance	100pF max. at 10kHz
Dielectric Strength	1500V 50Hz

ORDERING INFORMATION

TU2091
SERIES

PACKAGING

50 pieces in a sectioned box.

Line Transformers



FEATURES

- TLP13 transformers are designed for telecom line matching and isolation or modems V22 standard
- They conform to EN 41003 regulations

DIMENSIONS in millimeters

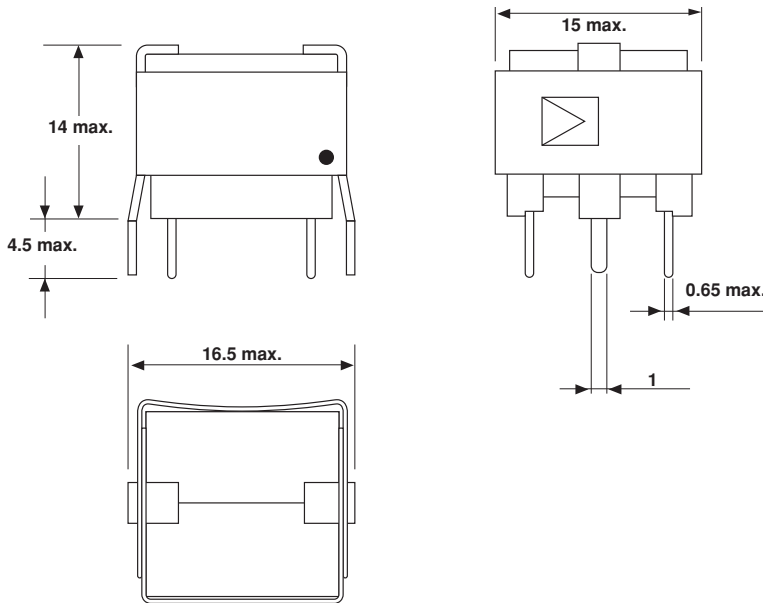

CONFIGURATION (TOP VIEW)

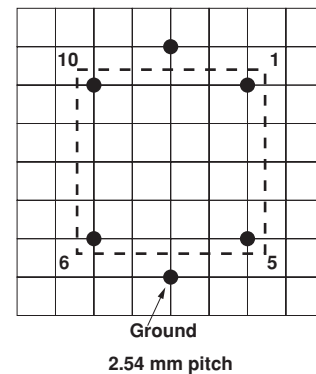

ELECTRICAL DIAGRAM

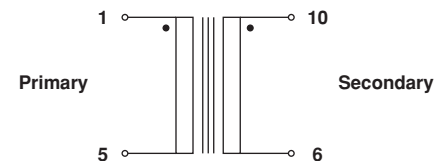

MECHANICAL SPECIFICATIONS

Ferrite	EP13 4 pins
Configuration	2.54mm pitch
Unit Weight	9g

CLIMATIC SPECIFICATIONS

Temperature Range Shelf	- 20°C + 105°C
Working	- 20°C + 85°C

MARKING

Print marked: manufacturer, series, model, manufacturing date (code), pin 1.

PACKAGING

50 pieces in a sectioned box.

ELECTRICAL SPECIFICATIONS

Dielectric Strength 4000VRMS

	TLP13-600	TLP13-300	TLP13-150
Output/Input Ratio S/P	1	0.707	0.5
Impedance Ratio	600/600	600/300	600/150
Minimum Primary Inductance	1.5H	1.5H	1.5H
Primary Inductance	60Ω	60Ω	60Ω
Secondary Inductance	60Ω	25Ω	14Ω
Leakage Inductance	10mH	10mH	10mH

Other values on request

ORDERING INFORMATION

TLP13	600
SERIES	MODEL

Line Transformers

V32 Characteristic 600/600Ω

FEATURES

- Conform to EN 41003 and EN 60950 regulations
- Potted in a case which gives high isolation and low cost
- Stick packing allows automatic insertion

DIMENSIONS in millimeters

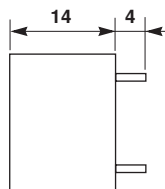
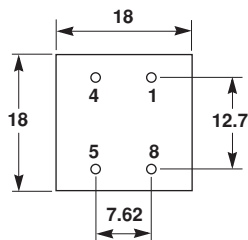
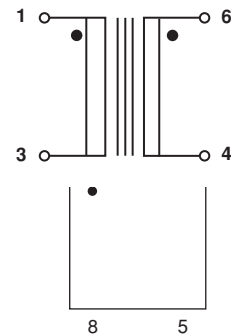
TA32

ELECTRICAL DIAGRAM

MECHANICAL SPECIFICATIONS

Configuration	2.54mm pitch
Case	UL 94 VO water proof
Unit Weight	10g

CLIMATIC SPECIFICATIONS

Temperature Range	
Shelf	- 20°C + 70°C
Working	- 10°C + 60°C

PACKAGING

25 pieces in stick.

MARKING

Print marked: manufacturer, series, manufacturing date (code), pin 1.

ELECTRICAL SPECIFICATIONS

Output/Input Ratio S/P	1/1
Primary Inductance at 200Hz	2.8H
Nominal Inductance:	
Primary	600Ω
Secondary	600Ω
Winding Resistance	
1-4	66Ω
5-8	66Ω
Insertion Loss (at 2kHz)	≤ 1.5 dB
Reflection Coefficient	
No load 0.2 to 4kHz	≥ 10 dB
In the net	≥ 21 dB
Shunt Loss	10kΩ
Signal Versus Frequency	0.2 to 3.5kHz
	- 0.3 dB
Signal in Wide Band	0.2 to 10kHz
	- 2.5 dB
Power Level	3 dB
Symmetry	0.3 to 5kHz
	> - 80 dB
Distortion	0 dB to 1kHz
	≤ 0.1%
Leakage Inductance	15mH
Dielectric Strength	6.5kVDC

ORDERING INFORMATION

TA32
SERIES

Line Transformers V34 Characteristic 600/600Ω



FEATURES

- Meets EN 41003 and EN 60950 specifications
- Can be used for line matching on V34 model
- SMD molding give an excellent dielectric strength and allow automatic pick and place

DIMENSIONS in millimeters

TA34

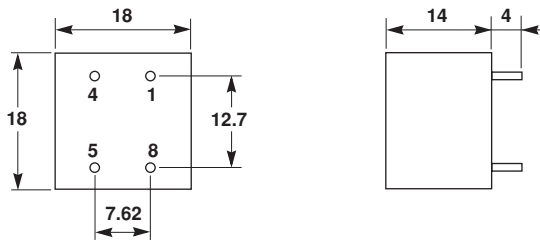

ELECTRICAL DIAGRAM

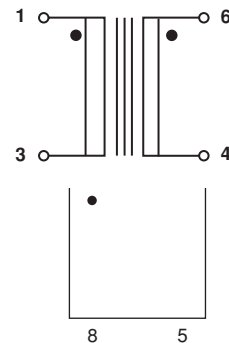

MECHANICAL SPECIFICATIONS

Configuration	2.54mm pitch
Case	UL 94 VO water proof
Unit Weight	10g

CLIMATIC SPECIFICATIONS

Temperature Range	
Shelf	- 20°C + 70°C
Working	- 10°C + 60°C

PACKAGING

25 pieces in stick.

MARKING

Print marked: manufacturer, series, manufacturing date (code), pin 1.

ELECTRICAL SPECIFICATIONS

Input/Output Ratio S/P	1/1
Primary Inductance at 1kHz	3H
Nominal Inductance:	
Primary	600Ω
Secondary	600Ω
Winding Resistance	
1-4	56Ω
5-8	56Ω
Insertion Loss (2kHz)	≤ 1.5 dB
Reflection Coefficient	
No load 0.2 to 4kHz	≥ 10 dB
In the net	≥ 21 dB
Shunt Loss	30kΩ
Signal Versus Frequency	0.2 to 3.5kHz
	- 0.3 dB
Signal in Wide Band	0.2 to 10kHz
	- 2.5 dB
Power Level	20 dB
Symmetry	0.3 to 5kHz
	> - 80 dB
Distortion	0 dB to 1kHz
	≤ 0.1%
Leakage Inductance	18mH
Dielectric Strength	6.5kVDC

ORDERING INFORMATION

TA34
SERIES

Line Transformers

V34 Characteristic 600/600Ω

FEATURES

- Meets EN 41003 and EN 60950 specifications
- Can be used for line matching on V34 model
- SMD molding give an excellent dielectric strength and allows automatic pick and place

DIMENSIONS in millimeters

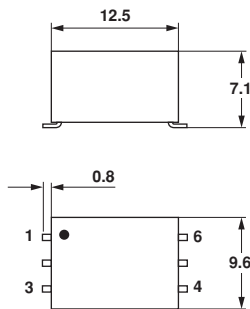
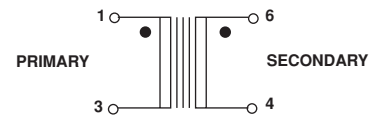
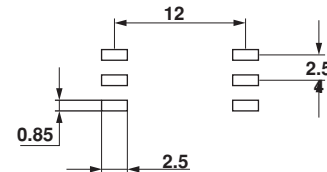
TA34M

ELECTRICAL DIAGRAM

SOLDER PADS

MECHANICAL SPECIFICATIONS

Configuration	2.54mm pitch
Case	UL 94 VO water proof
Unit Weight	10g

CLIMATIC SPECIFICATIONS

Temperature Range	
Shelf	- 20°C + 70°C
Working	- 10°C + 60°C

PACKAGING

250 pieces tape and reel.

MARKING

Print marked: manufacturer, series, manufacturing date (code), pin 1.

ELECTRICAL SPECIFICATIONS

Input/Output Ratio S/P	1/1
Primary Inductance	3.8H
Nominal Impedance:	
Primary	600Ω
Secondary	600Ω
Winding Resistance	
1-4	115Ω
5-8	115Ω
Insertion Loss (1kHz)	3 dB
Reflection Coefficient	0.2 to 4kHz
	24 dB
Shunt Loss	7500Ω min.
Signal Versus Frequency	0.2 to 4kHz
	± 0.25 dB
Symmetry	80 dB min.
Distortion	- 82 dB max. at 60Hz power level 10dBm
Leakage Inductance	6mH max.
Dielectric Strength	4600VRMS
Insulation Resistance	100MΩ at 500VDC

ORDERING INFORMATION
TA34M

SERIES

Line Transformers

V90 Characteristic 600/600Ω, Modem 56Kbps

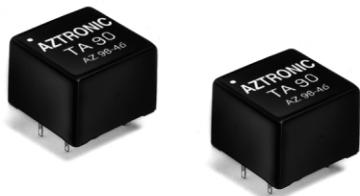

FEATURES

- Conform to EN 41003 and EN 60950 regulations
- Potted in a case which gives high isolation and low cost
- Stick packing allows automatic insertion

DIMENSIONS in millimeters

TA90

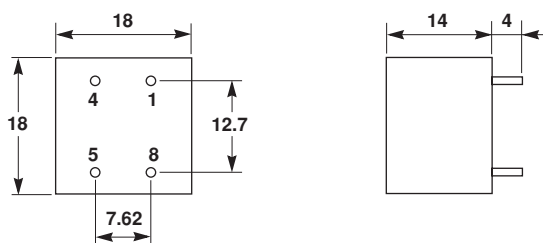

ELECTRICAL DIAGRAM

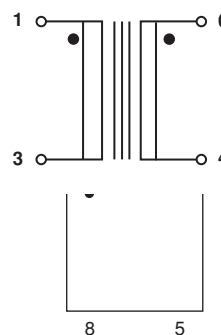

MECHANICAL SPECIFICATIONS

Configuration	2.54 pitch
Case	UL 94 VO water proof
Unit Weight	10g

CLIMATIC SPECIFICATIONS

Temperature Range	
Shelf	- 20°C + 70°C
Working	- 10°C + 60°C

PACKAGING

25 pieces in stick.

MARKING

Print marked: manufacturer, series, manufacturing date (code), pin 1.

ELECTRICAL SPECIFICATIONS

Input/Output Ratio S/P		1/1
Primary Inductance at 200Hz		14H
Nominal Impedance	Primary	600Ω
	Secondary	600Ω
Winding Resistance	1-4	100Ω
	5-8	100Ω
Insertion Loss (at 2kHz)		2.5 dB typical
Reflection Coefficient	No load 0.2 to 4kHz	≥ 16 dB
	In the net	≥ 21 dB
Shunt Loss		25kΩ typical
Signal Versus Frequency	from 0.1 to 4kHz	± 0.6 dB
Signal in Wide Band	from 0.01 to 6kHz	- 3 dB
Power Level		20 dB
Symmetry	0.3 to 5kHz	> - 80 dB
Distortion	0 dB to 1kHz	≤ 0.1%
Leakage Inductance		25mH
Dielectric Strength		6.5kVDC

ORDERING INFORMATION

TA90
SERIES



Model Numbers	
TCM50	68
TCP7.....	69
TCB	71
TCH.....	72

Current Transformers

Current Micro-Transformers

•
Low Frequency and
High Frequency Models

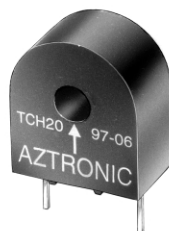
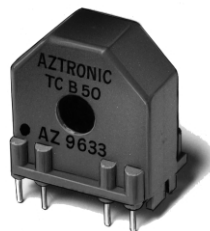

Current Transformers

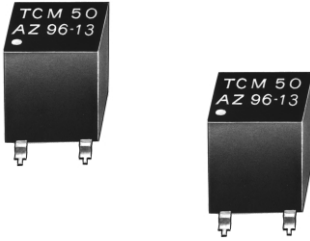

DIMENSIONS in millimeters

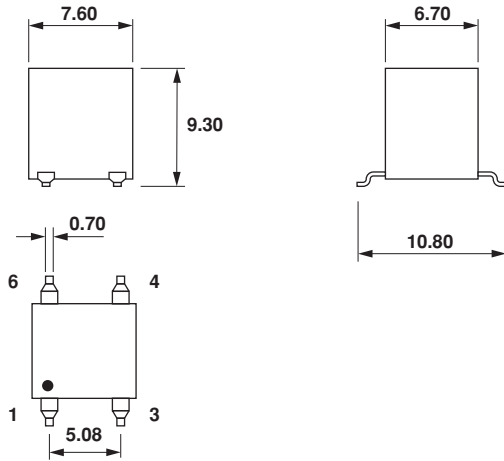

MECHANICAL SPECIFICATIONS

Case	UL 94 V0
Max. Unit Weight	1g

CLIMATIC SPECIFICATIONS

Temperature Range Shelf	- 55°C + 85°C
Working	- 30°C + 75°C

MEASUREMENT CONDITIONS

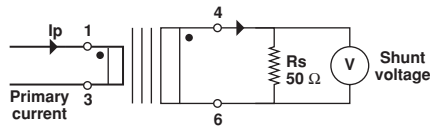

PACKAGING

Tape 24mm width, 16mm pitch.
500 pieces/reel: external dia: 330mm
height: 31mm

MARKING

Print marked: series, model, manufacturer, manufacturing date (code), pin 1.

ORDERING INFORMATION

TCM50
SERIES AND MODEL

FEATURES

- Current microtransformers are designed for AC measurement up to 100kHz
- Main application is current measurement or limitation for switching power supply or DC/DC converter
- Tape and reel packaging allows automatic pick and place

ELECTRICAL DIAGRAM

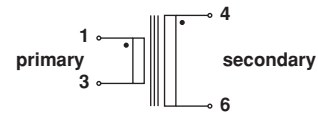

RECOMMENDED SOLDERING PAD

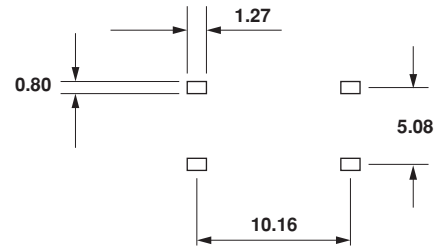

ELECTRICAL SPECIFICATIONS

Maximum Frequency	100kHz
Insulation Voltage	500VRMS 1mn
Maximum Primary Current	On 50Ω Load to Add to the Circuit 2 A RMS
Secondary Resistance	1.1Ω ± 20%
Secondary Inductance	1.6μH ± 25%

SHUNT VOLTAGE VERSUS FREQUENCY

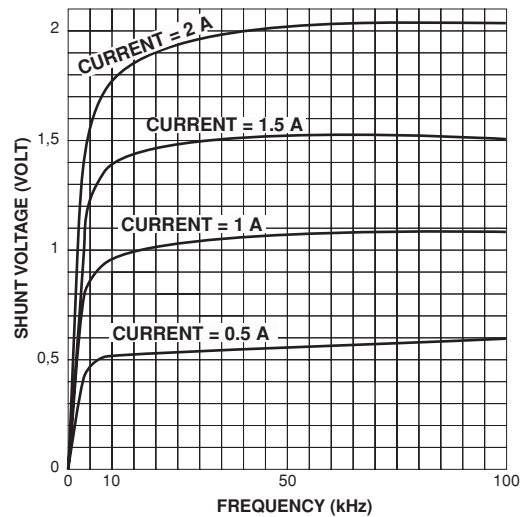

SMD Current Transformers

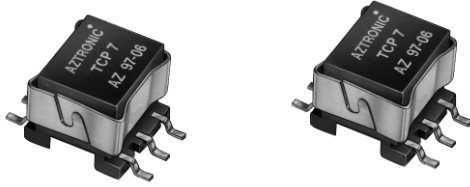

FEATURES

- TCP7 transformer is designed for AC current measurement for frequencies from 20kHz to 200kHz with complete isolation of circuits
- Main applications: DC/DC converter, switching power supplies or any electronic device
- Tape and reel packaging allows automatic pick and place

DIMENSIONS in millimeters

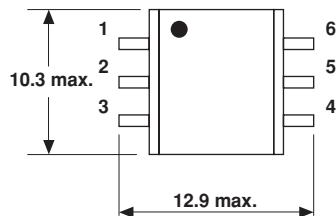
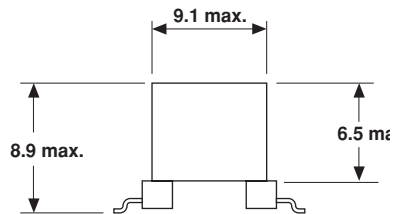

RECOMMENDED SOLDERING PAD

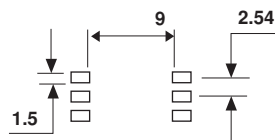

ELECTRICAL DIAGRAM

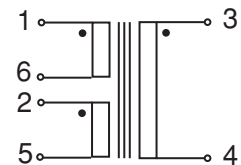

TYPICAL APPLICATION

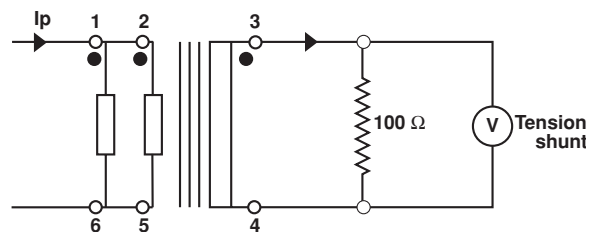

MECHANICAL SPECIFICATIONS

Ferrite	EP7
Case	SMD shell
Configuration	6 pins
Unit Weight	2g

CLIMATIC SPECIFICATIONS

Working Temperature Range - 20°C + 85°C

ELECTRICAL SPECIFICATIONS

Frequency Range	20kHz to 200kHz
Dielectric Strength	1500VRMS
Primary Resistance 1-6//2-5 max	10MΩ
Secondary Resistance 3-4 max	4.2Ω
Maximum Primary Current	5A
On 100Ω load to add to the circuit	
Primary Peak Current	15A

FREQUENCY VERSUS VOLTAGE

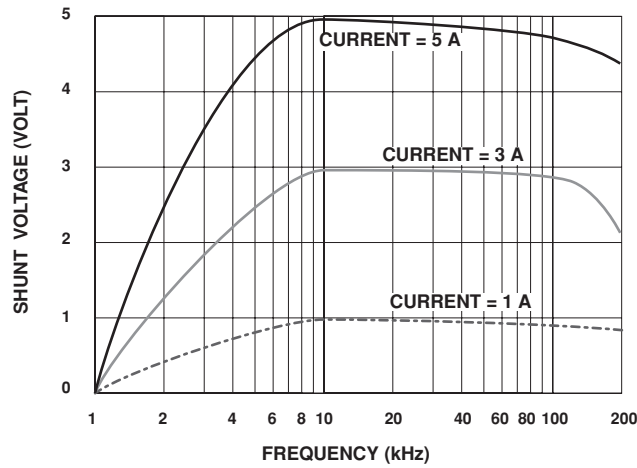

CURRENT VERSUS VOLTAGE

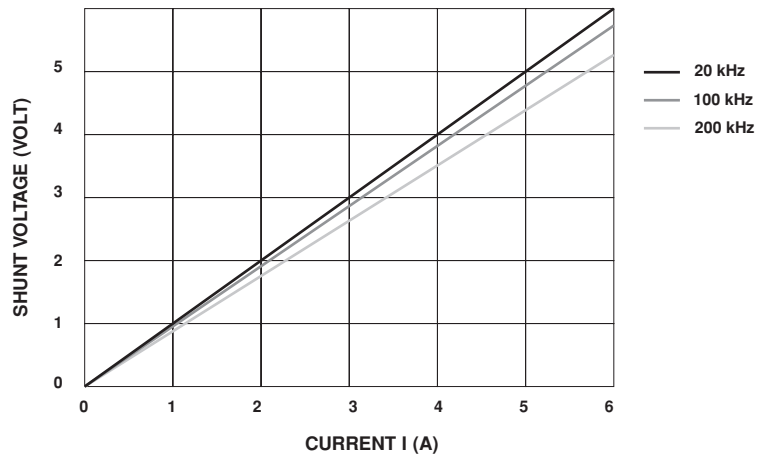

PACKAGING

250 pieces tape and reel

MARKING

Print marked: manufacturer, series, manufacturing date (code), pin 1.

ORDERING INFORMATION

TCP7

SERIES

Low Frequency Current Transformers

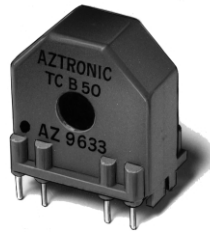

FEATURES

- TCB transformers are designed for AC current measurement for frequencies from 50Hz to 400Hz
- Used for measurement or current limitation for electrical appliances powered by main supply 50/60Hz or low frequency transformers such as motors and heaters
- Measurement is done using a lead going through the center of the transformer
- No temperature rise, no disturbance can be noted

DIMENSIONS in millimeters

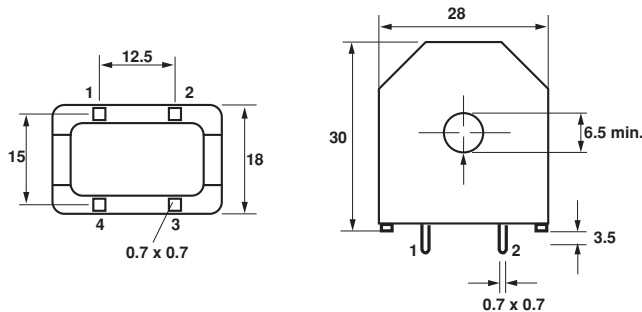

TYPICAL APPLICATION

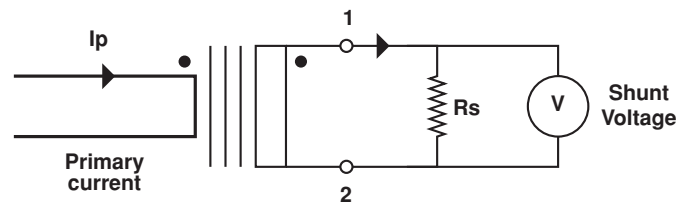

MECHANICAL SPECIFICATIONS

Case UL 94 V0
 Unit Weight 21g

CLIMATIC SPECIFICATIONS

Temperature Range: Shelf - 55°C + 85°C
 Working - 30°C + 75°C

MARKING

Print marked: series, model, manufacturer, manufacturing date (code). Arrow showing reference for phase matching with winding 1-2.

ELECTRICAL SPECIFICATIONS

Frequency Range 50Hz/400Hz
 Insulation 2k VRMS, 4k VRMS on request

	TCB 50		TCB 70		TCB 100	
Ratio	1: 500		1: 700		1: 1000	
Shunt Resistance to Add to the Circuit RS (Ω)	33	150	50	200	50	200
Primary Current max. (A)	50	12	70	16	100	25
Ratio Shunt Voltage (V) / Primary Current (A)	0.07	0.30	0.071	0.286	0.05	0.2
Winding Resistance 1-2 (Ω)	18.5		33		75	

TCB 50 with shunt 33Ω

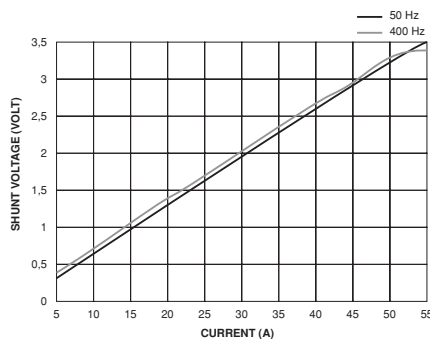

TCB 70 with shunt 50Ω

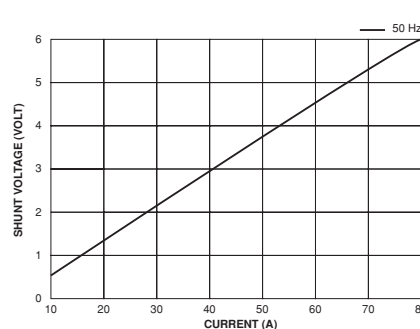

TCB 100 with shunt 50Ω

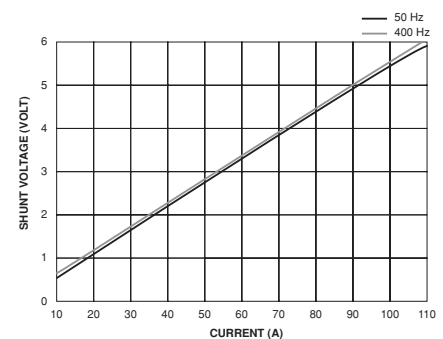

PACKAGING

50 pieces in a sectioned box

ORDERING INFORMATION

TCB
 SERIES

50
 MODEL

High Frequency Current Transformers



FEATURES

- TCH current transformers are designed for AC current measurement for frequencies from 20kHz to 100kHz or current limitation on switching power supplies or DC/DC converters
- Measurement is done using a lead going through the center of the transformer
- No temperature rise, no disturbance can be noted

DIMENSIONS in millimeters

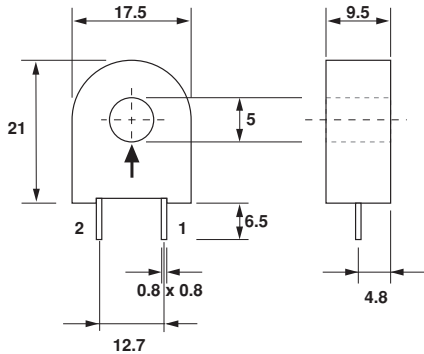

TYPICAL APPLICATION

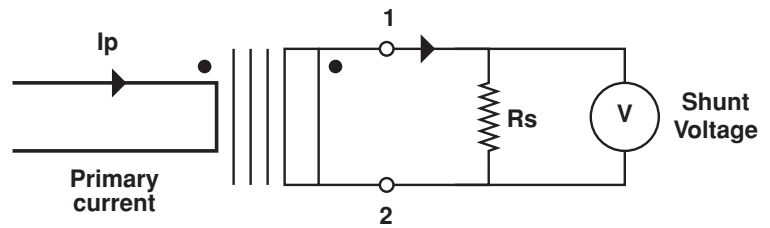

MECHANICAL SPECIFICATIONS

Case UL 94 V0
 Unit Weight 6g

CLIMATIC SPECIFICATIONS

Temperature Range Shelf -55°C + 85°C
 Working -30°C + 75°C

MARKING

Print marked: manufacturer, series, model, manufacturing date (code). Arrow showing reference for phase matching with 1-2 winding.

ELECTRICAL SPECIFICATIONS

Frequency Range 20kHz/100kHz
 Insulation 4k VRMS

	TCH 5		TCH 10		TCH 20	
Ratio	1: 50		1: 100		1: 200	
Shunt Resistance to Add to the Circuit RS (Ω)	50	1000	50	1000	50	1000
Primary Current max. (A)	5	1	10	2	20	4
Ratio Shunt Voltage (V) / Primary Current (A)	1	20	0.5	10	0.25	5
Winding Resistance 1-2 (Ω)	0.20		1.5		11.5	

TCH 5 with shunt 50Ω

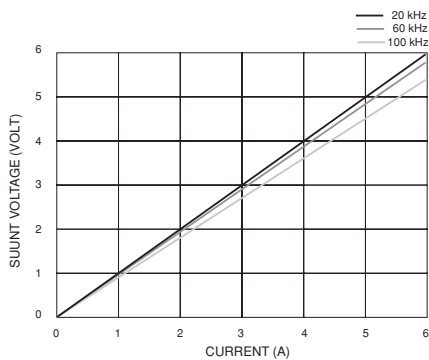

TCH 10 with shunt 50Ω

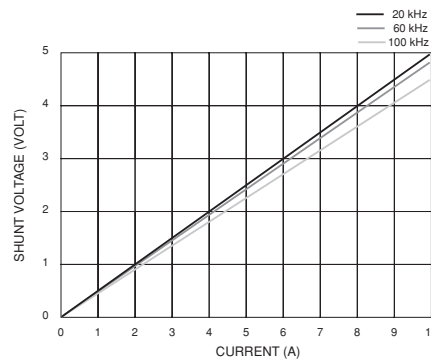

TCH 20 with shunt 50Ω

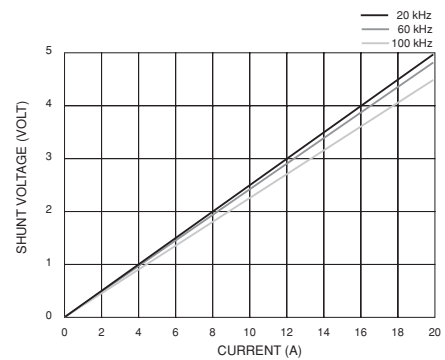

PACKAGING

50 pieces in a sectioned box

ORDERING INFORMATION

TCH
 SERIES

10
 MODEL



Model Numbers	
TAZ	74
TMS	76
TRC 100, 200	78
TRH	79

Power Supply Transformers

Toroidal and Safety Transformers

•
Low Profile Models



Toroidal Transformers



FEATURES

- NFC 52200
- 10 sizes with power ratings from 15 to 500 watts
- TAZ toroidal transformers are designed for 50/60Hz power supplies used for electronic circuitry
- Performance and geometry of magnetic core give an excellent efficiency and very low radiation
- Parts are delivered with ring washers for easy assembly

DIMENSIONS in millimeters

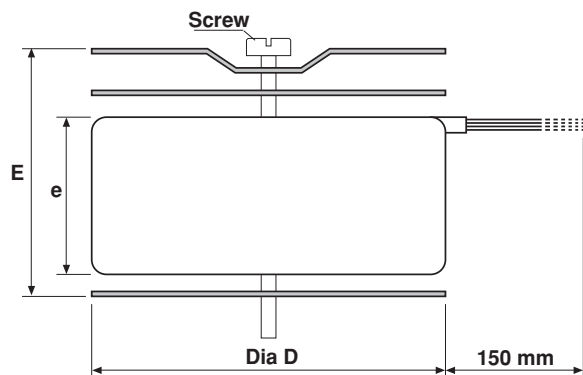

SERIES	DIMENSIONS in mm			SCREW	UNIT WEIGHT Kg
	Dia D	e	E		
TAZ 15	63	31	36	M 4 x 40	0.32
TAZ 30	72	32	37	M 4 x 40	0.52
TAZ 50	82	33	38	M 6 x 40	0.73
TAZ 80	90	42	47	M 6 x 50	1.0
TAZ 120	102	37	42	M 6 x 50	1.5
TAZ 160	105	43	48	M 6 x 50	1.7
TAZ 200	118	42	47	M 8 x 50	2.1
TAZ 250	125	60	65	M 8 x 70	3.0
TAZ 300	130	60	65	M 8 x 70	3.4
TAZ 500	145	55	60	M 10 x 60	4.3

ELECTRICAL SPECIFICATIONS

Primary Voltage	115VRMS parallel windings 230VRMS series windings
Frequency Range	50 or 60Hz
Dielectric strength	2500VRMS

MECHANICAL SPECIFICATIONS

Assembly	screwed and tied by ring washer and 2 soft washers
Connection	wire with colored sleeves
Protection	polyester ribbon

CLIMATIC SPECIFICATIONS

Temperature Range	0°C to + 70°C
-------------------	---------------

SPECIAL FEATURES ON REQUEST

- Primary/secondary shield
- Flexible leads
- Impregnation
- Connector
- Specific voltages
- Specific sizes.

ELECTRICAL DIAGRAM

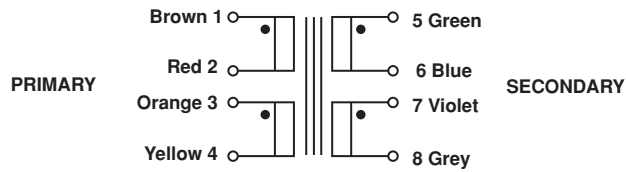

CONNECTION FOR 230V MAIN SUPPLY

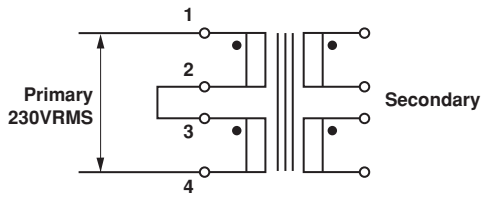

CONNECTION FOR 115V MAIN SUPPLY

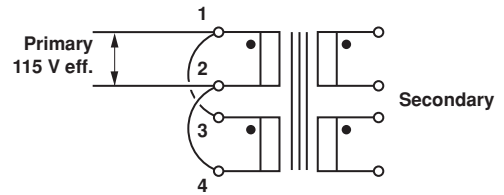

SERIES AND MODEL	POWER W	CURRENT (A)					
		2 x 6V	2 x 9V	2 x 12V	2 x 15V	2 x 24V	2 x 48V
TAZ 15	15	1.3	0.84	0.63	0.50	0.32	0.16
TAZ 30	30	2.5	1.7	1.3	1.0	0.63	0.32
TAZ 50	50	4.2	2.8	2.1	1.7	1.1	0.53
TAZ 80	80	6.7	4.5	3.4	2.7	1.7	0.84
TAZ 120	120	10	6.7	5	4	2.5	1.25
TAZ 160	160	13.4	8.9	6.7	5.4	3.4	1.7
TAZ 200	200	16.7	11.1	8.4	6.7	4.2	2.1
TAZ 250	250	20.8	13.9	10.4	8.4	5.2	2.6
TAZ 300	300	25.0	16.7	12.5	10.0	6.3	3.2
TAZ 500	500	41.7	27.8	20.9	16.7	10.4	5.2

PACKAGING
In a box with screw, ring washer and 2 soft washers.

MARKING
Label with manufacturer, series, model, manufacturing date (code), schematic.

ORDERING INFORMATION		
TAZ	30W	2 x 6V
SERIES	MODEL	SECONDARY VOLTAGE

Mains Transformers



FEATURES

- Potted in a case to be mounted on a PCB
- Potting gives a high isolation and good aging
- Pins are on a standard 5mm pitch

DIMENSIONS in millimeters

TMS 0.5 / 1 / 1.2 / 1.8 / 2.5

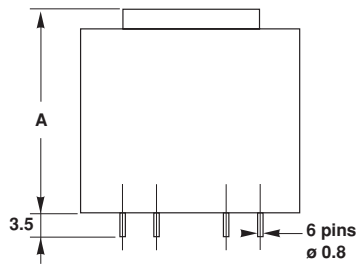
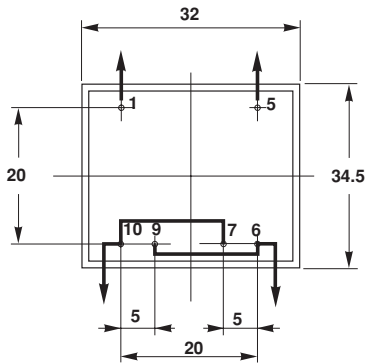

TMS 3.2

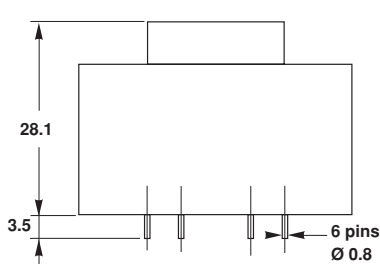
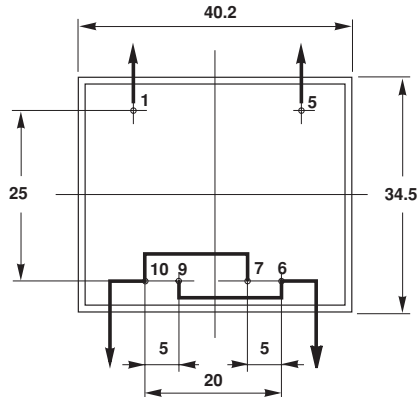

TMS 5

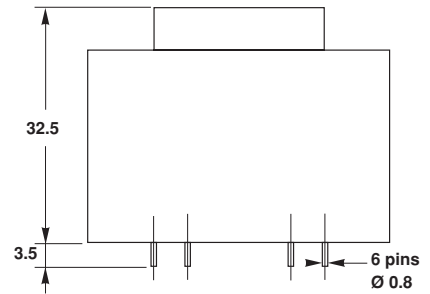
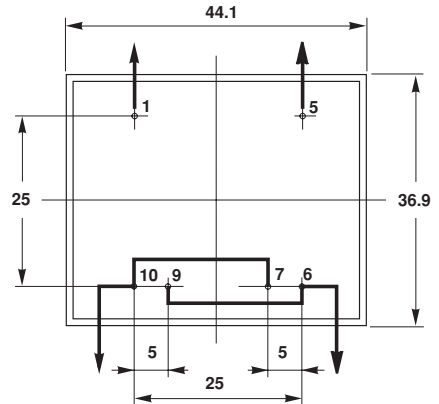

ELECTRICAL DIAGRAMS

1 SECONDARY

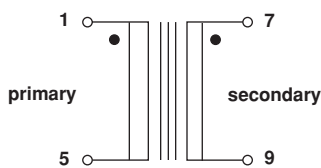

2 SECONDARIES

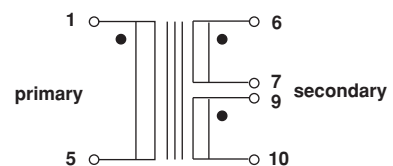

**MECHANICAL SPECIFICATIONS**

Case UL 94 VO compound

CLIMATIC
 Temperature Range
 Shelf - 40°C + 120°C
 Working - 20°C + 70°C
ELECTRICAL SPECIFICATIONS

Dielectric Strength	400VRMS
Primary/Secondary	230VRMS 50/60Hz
Primary Voltage	external fuse
Electrical Protection	

TECHNICAL SPECIFICATIONS

SERIES AND MODEL	TMS 0.5	TMS 1	TMS 1.2	TMS 1.8	TMS 2.5	TMS 3.2	TMS 5
Size	EI 30	EI 30	EI 30	EI 30	EI 30	EI 38	EI 42
Power (W)	0.5	1.0	1.2	1.8	2.5	3.2	5
Temporized Fuse (A)	–	–	–	–	–	0.032	0.032
Unit Weight (g)	42	70	80	96	110	150	195
High A (mm)	15,3	21.8	23.8	26.8	29.5	28.1	32.5
Maximum Permanent Current (1 Secondary) 7 - 9 mA	6V	83	166	200	300	417	533
	9V	55	110	133	200	277	355
	12V	41	82	100	150	209	266
	15V	33	66	80	120	167	213
	18V	27	54	66	100	139	179
	24V	21	42	50	75	104	133
Maximum Permanent Current (2 Secondaries) 6 - 7 + 9 - 10 mA	2 x 6V	41	82	100	150	208	266
	2 x 9V	27	54	66	100	139	178
	2 x 12V	21	42	50	75	104	133
	2 x 15V	17	34	40	60	83	107
	2 x 18V	14	28	33	50	69	89
	2 x 24V	11	22	25	37	52	67

Other voltages on request

PACKAGING

In box.

MARKING

Print marked: manufacturer, series, model, customer specifications, manufacturing date (code).

ORDERING INFORMATION

TMS	1.2	1 x 12V
SERIES	POWER	SECONDARY VOLTAGE

Low Profile Planar Transformers



FEATURES

- 2 sizes, 150 watt and 300 watt and 3 below
- <<PLANAR>> transformers TRC series are designed for switching power supplies and DC/DC converters with a low profile requirement
- Transformer thickness gives high shock and vibration performance and excellent heat dissipation
- Windings are either made from a combination of PC boards, copper straps or thermo adhesive wire which allows high frequency use and optimizes weight in relation to power

DIMENSIONS in millimeters

TRC 100

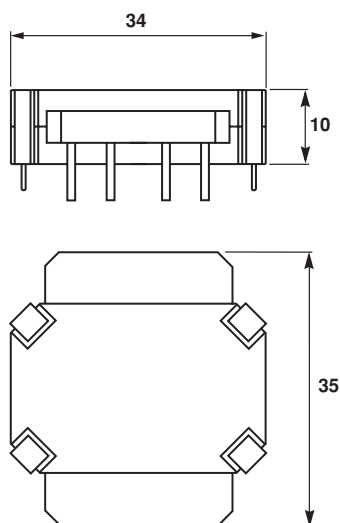

TRC 200
47

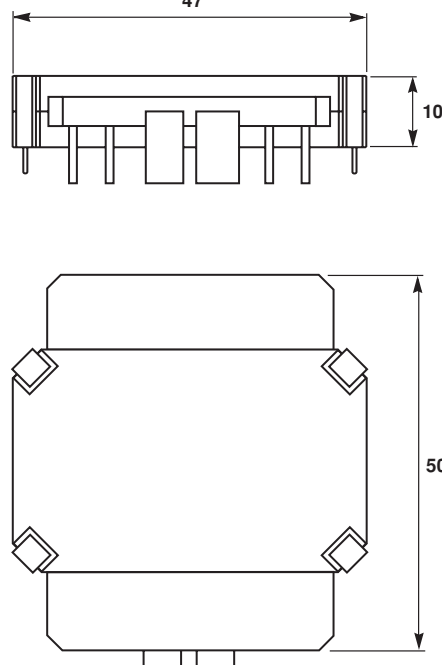

MECHANICAL SPECIFICATIONS

Mounting	PC pins
Terminals	brass solder coated
Unit Weight	TRC 100 35g TRC 200 70g

CLIMATIC SPECIFICATIONS

Temperature Range Shelf	- 55°C + 125°C
Working	- 40°C + 125°C

ELECTRICAL SPECIFICATIONS

Maximum Power	TRC 100 150W TRC 200 300W
Maximum Frequency	300kHz
Dielectric Strength	1000VRMS

MARKING

Print marked: manufacturer, series, model, customer reference, manufacturing date (code).

ORDERING INFORMATION

TRC	100	
SERIES	MODEL	CUSTOMER REFERENCE

Low Profile Transformers

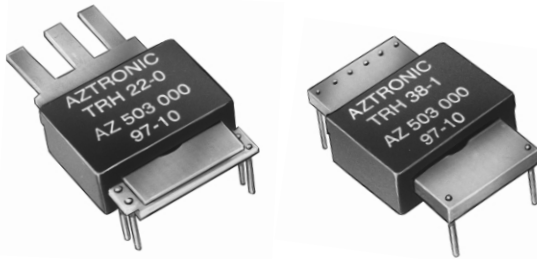

FEATURES

- <<PLANAR>> transformer TRH series are designed for switching power supplies and DC/DC converters with a low profile requirement
- Transformer thickness gives high shock and vibration performance and excellent heat dissipation
- Windings are either made from a combination of PC boards, copper straps or thermo adhesive wire which allows high frequency use and optimizes weight in relation to power

DIMENSIONS in millimeters

PC BOARD PIN OUT

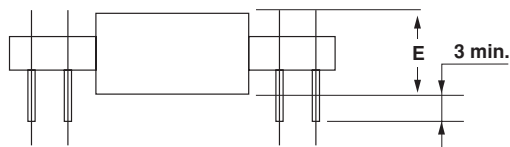
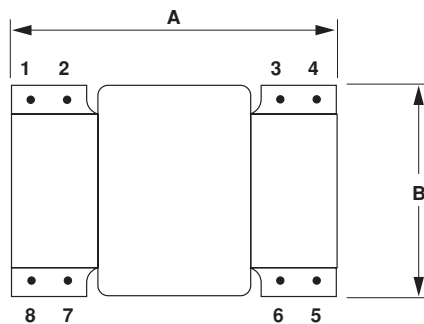

COPPER STRAPS PIN OUT

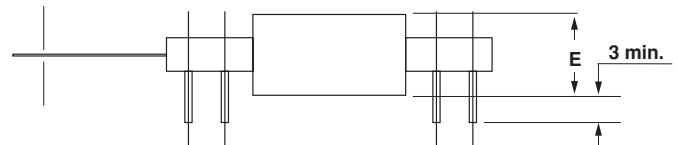
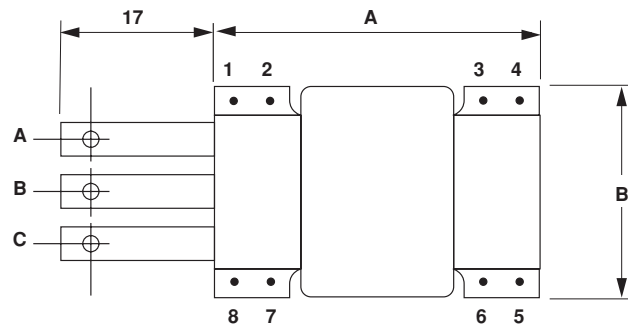

MODEL	POWER W	Dimensions in mm		
		A	B	E
TRH 22 0	90	34	22	8.5
22 1	150			12
TRH 32 0	250	38	32	10
32 1	350			13
TRH 38 0	600	48	39	12.5
38 1	900			17
TRH 43 0	900	60	44	14
43 1	1400			20
TRH 58 0	1900	80	59	15
58 1	2900			22
TRH 64 0	3400	93	65	16
64 1	5000			21

MECHANICAL SPECIFICATIONS

- Holding** mounting frame
Terminals pins or copper strap

MARKING

Print marked: manufacturer, series, model, customer specifications, manufacturing date (code).

ORDERING INFORMATION

SERIES	MODEL	CUSTOMER SPECIFICATIONS
TRH	38 1	







WORLDWIDE SALES CONTACTS

DISCRETE SEMICONDUCTORS AND PASSIVE COMPONENTS

THE AMERICAS

VISHAY AMERICAS

ONE GREENWICH PLACE
SHELTON, CT 06484
UNITED STATES
PH: +1-402-563-6866
FAX: +1-402-563-6296

ASIA

VISHAY INTERTECHNOLOGY ASIA PTE LTD.

25 TAMPINES STREET 92
KEPPEL BUILDING #02-00
SINGAPORE 528877
PH: +65-6788-6668
FAX: +65-6788-0988

JAPAN

VISHAY JAPAN CO., LTD.

GE EDISON BUILDING, SHIBUYA 3F
3-5-16 SHIBUYA
SHIBUYA-KU
TOKYO 150-0002
JAPAN
PH: +81-3-5464-6411
FAX: +81-3-5464-6433

EUROPE

VISHAY ELECTRONIC GMBH

GEHEIMRAT-ROSENTHAL-STR. 100
95100 SELB
GERMANY
PH: +49-9287-71-0
FAX: +49-9287-70435

VISHAY S.A.

4, RUE DE SALONIQUE
95101 ARGENTEUIL
FRANCE
PH: +33-1-39-98-22-00
FAX: +33-1-39-98-22-05

VISHAY LTD.

PALLION INDUSTRIAL ESTATE
SUNDERLAND, SR4 6SU
GREAT BRITAIN
PH: +44-191-514-4155
FAX: +44-191-567-8262

ONLINE INFORMATION

For product information and a current list of sales offices,
representatives and distributors, visit our website:

www.vishay.com

ONE OF THE WORLD'S LARGEST MANUFACTURERS OF DISCRETE SEMICONDUCTORS AND PASSIVE COMPONENTS



VISHAY INTERTECHNOLOGY, INC.

World Headquarters

63 Lincoln Highway
Malvern, PA 19355-2143
United States

www.vishay.com

© Copyright Vishay Intertechnology, Inc.
Registered Trademarks of Vishay Intertechnology, Inc.
All rights reserved. Printed in the United States.
Specifications subject to change without notice.

Databook VSD-DB0039-0210